

# ABS Piranha submersible grinder pump 08-110

ABS submersible pumps for problem-free pumping of sewage containing faecal matter in pipe lines from 1¼" (DN 32) in accordance with EN 12050-1.

## Applications

Piranha submersible pumps have been designed for effective and economic dewatering using discharge lines of small diameter, in private, municipal and industrial areas.

- Sewage removal from living units and houses in remote settlements where the laying of a conventional sewer would be too expensive, where large ground undulations are present or where it is only possible to lay pipe lines of small diameter.
- Sewage removal from motorway resting sites, communal buildings and for renovation of buildings or areas of a city.
- For use in slaughter houses, food processing plants, paper factories, agriculture and similar areas.
- Piranha 08 and 09 are specially designed for private and domestic applications.
- Maximum allowable temperature of the medium for continuous operation is 40 °C.

## Construction

The water pressure-tight, encapsulated fully flood-proof motor and the pump section form a compact, robust, unit construction.

## Bearings

The stainless steel motor shaft is supported in lubricated-for-life ball bearings.

## Shaft sealing

Piranha 08 - S26: Between motor and hydraulic section by means of a high quality sealing unit using a silicon carbide mechanical seal. Seal at motor side is by oil lubricated lip seal.

Piranha PE30/2C - 110/2E: Double mechanical seals, SiC-SiC at the hydraulic side, SiC-C at the motor.

All seals are independent of direction of rotation and resistant to temperature shock

## Discharge

Piranha 08 and 09: G 1¼" internal thread

Piranha S10 to S26 and PE30/2C: DN 32 flange (G 1¼" threaded adaptor available as accessory)

Piranha PE55/2E to PE110/2E: DN 50 with DIN-flange

## Shredding system

Spiral bottom plate and stationary cutter ring combined with a shredding rotor located before the impeller, for optimum blockage-free running.

## Temperature monitoring

TCS (Thermo-Control-System) with thermal sensors in the stator to switch off the pump in the case of overheating and switch on automatically after cooling down (optional for non-Ex Piranha S model).

## Seal monitoring

DI system consisting of a sensor in the motor and oil chambers which signals an inspection alert if there is leakage at the shaft seals (not in oil chamber on Ex version). Not available for Piranha 08 and 09; optional for non-Ex Piranha S model.



## Features

- Unique ABS Piranha shredding system capable of shredding items such as cloths and plastic bags.
- For the pumping of wastewater containing sewage, offal, organic and industrial effluent.
- Piranha 08 and 09 fitted with MF modular motor; Piranha-S with AS, Piranha PE with XFP Premium Efficiency IE3.
- Piranha 08 and 09 available as KS version with float switch.
- Small discharge lines from 1¼" (DN 32).
- Installations are possible where large ground undulations are present.
- Standard and Ex-versions.
- Piranha 08 and 09 have capacitor in upper lid and do not require a control box.
- Low installation costs due to small diameter discharge pipe-work.

## Motor

Three-phase 400 V or single-phase 220-240 V, 50 Hz, 2-pole (2900 r/min) or 4-pole (1450 r/min).

Cooled by amply dimensioned cooling areas.

Piranha 08: insulation class F, protection type IP 68, non-Ex only.  
Piranha S10 - 26: insulation class F, protection type IP 68, Ex and non-Ex.

Piranha PE 30/2C - 100/2E: Premium Efficiency IE3 with NEMA Class A temperature rise, insulation class H, protection type IP 68, Ex only.

Explosive-proof versions are in accordance with EEXd IIB T4 and ATEX international standards.

## Materials

Description	Material
Upper Lid *	Stainless steel 1.4301 (AISI 304)
Motor Housing	Cast iron EN-GJL-250
Rotor Shaft	Stainless steel 1.4021 (AISI 420)
Volute	Cast iron EN-GJL-250
Impeller **	Cast iron EN-GJL-250
Fasteners	Stainless steel 1.4401 (AISI 316)

\* Piranha 08 and 09

\*\* Polyamide for Piranha 08

## Technical Data

Piranha	Discharge		Motor power **		Rated current (A)	Rated voltage (V)	Speed (r/min)	Cable size ***	Weight **** (kg)
	Flange DN	Internal thread *	P <sub>1</sub>	P <sub>2</sub>					
08 W	-	G 1¼"	1.41	1.00	6.41	220-240 1~	2900	3G1.0	18
08 D	-	G 1¼"	1.34	1.00	2.71	400 3~	2900	4G1.0	18
09 W	-	G 1¼"	2.56	1.84	11.60	220-240 1~	2900	3G1.0	23
09 D	-	G 1¼"	2.56	2.00	4.64	400 3~	2900	4G1.0	23
S10/4 W <sup>(1)</sup>	32	G 1¼"	1.69	1.00	7.49	220-240 1~	1450	4G1.5	32
S12/2 W <sup>(1)</sup>	32	G 1¼"	1.77	1.20	8.22	220-240 1~	2900	4G1.5	32
S12/2 D	32	G 1¼"	1.69	1.20	3.29	400 3~	2900	4G1.5	32
S13/4 D	32	G 1¼"	1.93	1.30	3.60	400 3~	1450	4G1.5	32
S17/2 W <sup>(1)</sup>	32	G 1¼"	2.36	1.65	10.60	220-240 1~	2900	4G1.5	32
S17/2 D	32	G 1¼"	2.31	1.70	3.97	400 3~	2900	4G1.5	32
S21/2 D	32	G 1¼"	2.79	2.10	4.75	400 3~	2900	4G1.5	37
S26/2 D	32	G 1¼"	3.43	2.60	5.64	400 3~	2900	4G1.5	40
PE30/2C D	32	G 1¼"	4.58	4.02	6.23	400 3~	2900	7G1.5	85
PE55/2E D	50 DIN	-	6.08	5.50	10.30	400 3~	2900	10G1.5	130
PE70/2E D	50 DIN	-	7.74	7.00	13.50	400 3~	2900	10G1.5	130
PE90/2E D	50 DIN	-	9.39	8.50	16.30	400 3~	2900	10G1.5	145
PE110/2E D	50 DIN	-	12.10	11.00	20.10	400 3~	2900	10G1.5	145

\* Piranha S10-26 and PE30/2C with threaded flange adaptor as accessory \*\* P<sub>1</sub> = Power at mains; P<sub>2</sub> = Power at motor shaft

\*\*\* Piranha S10 Ex and Piranha S10-26 with Di and klixon: 7G1.5 \*\*\*\* Weight with 10 m cable

<sup>(1)</sup> Start and Run capacitor to the following specification required for use without control panel.  
Start: 125-160µF  
Run: 40µF (2x20µF) for S10/4W, 30µF for S12/2W and S17/2W  
The recommended start time for the motors is two seconds.

## Performance Curves

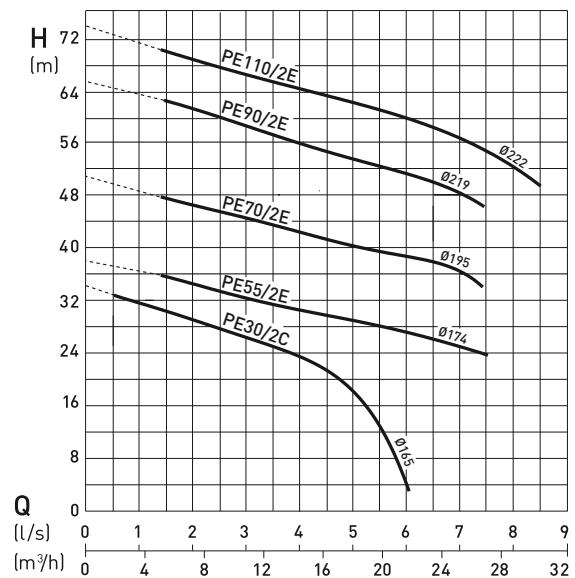
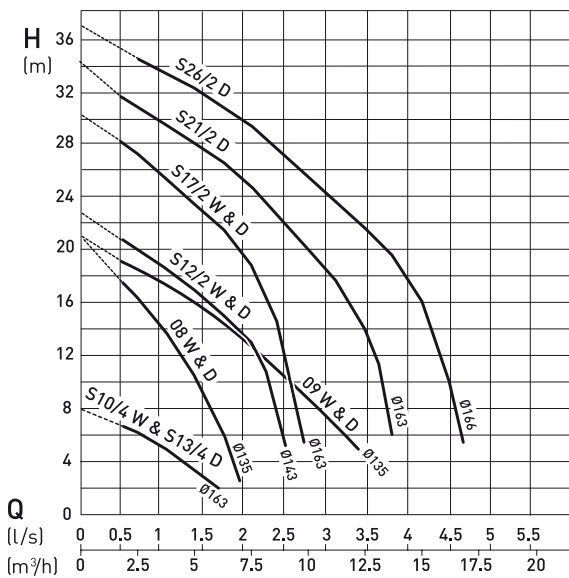

H = Total Head; Q = Discharge Volume. Curves to ISO 9906 (60 Hz available on request) N.B. please use the ABSEL program to validate pump selection.

Dimensions (mm)

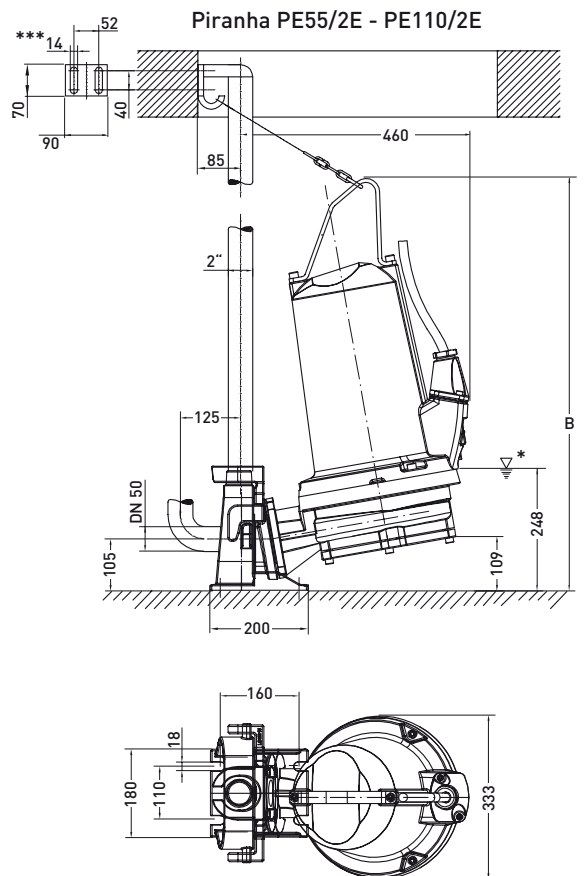
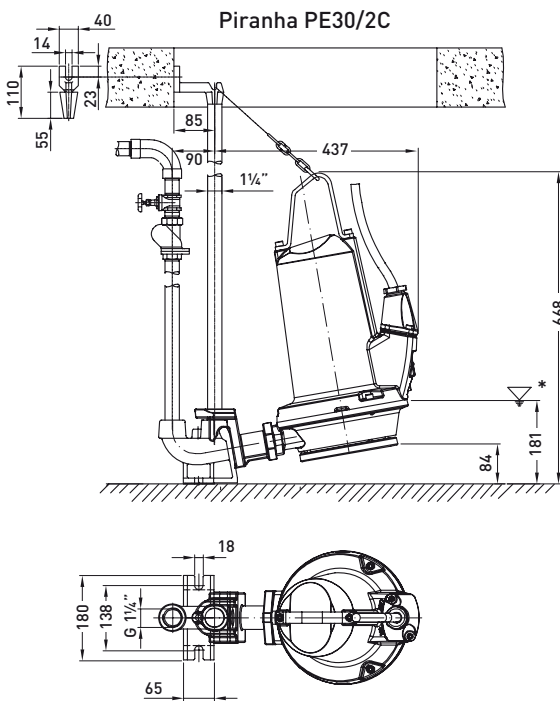
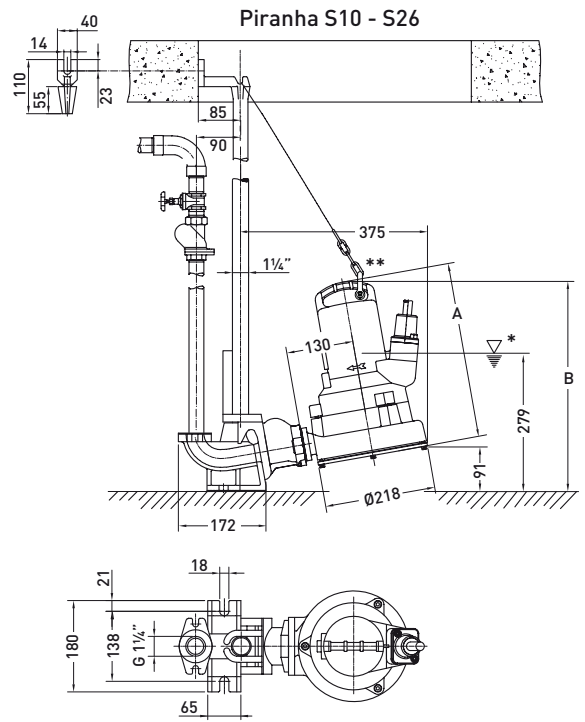
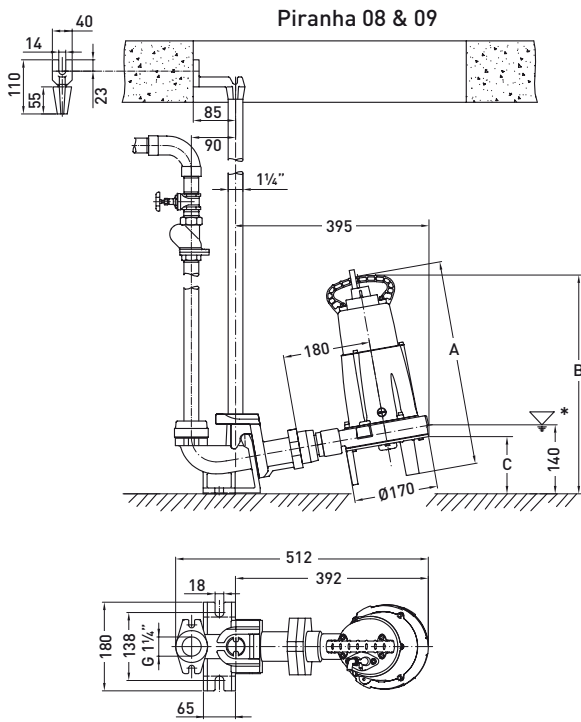

Piranha	A	B	C
08	420	445	117
09	445	470	108
S10 - S17	347	414	-
S21 - S26	360	427	-
PE55/2E - PE90/2E	-	774	-
PE110/2E	-	844	-

Piranha 08 - PE110/2E: Minimum sump opening Ø625 mm  
 Pedestal base secured using M10 masonry anchor bolts,  
 drill hole size 14 mm  
 \* Lowest switch-off point for automatic operation

Piranha S10 - S26: \*\* To allow the pump to be lowered and fixed correctly to the pedestal,  
 the shackle must be fixed to the handle at the point furthest  
 from the guide rail.

Piranha PE55/2E - PE110/2E: Discharge line connection with threaded flange DN 50/2" PN16  
 Discharge elbow supplied by customer  
 \*\*\* Hexagon head wood screw 10 x 70 DIN 571 and dowel size 12

## Accessories

	Description	Size	Part no.	Piranha	
<b>Fixed installation with pedestal</b>	<b>Pedestal</b> (EN-GJL-250) 90° cast bend	G 1¼"	62325007	08 & 09	
		G 1¼"	62320674	S10-S26	
		G 1¼"	62320676	PE30/2C	
		90° cast bend with built-in non-return valve	G 1¼"	62320536 62320538	S10-S26 PE30/2C
		without bend	DN 50/G2"	62320660	PE55/2E-110/2E
		<b>Threaded Adaptor</b> hexagon double nipple	G 1¼"	13770011	08 & 09
		<b>Guide Rail</b> (galvanized steel)	1¼" x 1 m	31380007	08-S26, PE30/2C
	1¼" x 2 m		31380008		
	1¼" x 3 m		31380009		
	1¼" x 4 m		31380010		
	1¼" x 5 m		31380011		
		<b>Chain Kit</b> (galvanized steel) including shackle	3 m	61265065	08-PE110/2E
	4 m		61265093		
6 m	61265069				
7 m	61265096				
	<b>Chain Kit</b> (stainless steel) including shackle	3 m	61265081	08-PE110/2E	
4 m		61265099			
6 m		61265085			
7 m		61265102			
<b>Transportable applications</b>	<b>Threaded Flange Kit</b> (EN-GJL-250) including discharge piece, gasket and bolts	G 1¼"	61180512	S10-PE30/2C	
	<b>Ground Support Stand</b> (St. 37) with fixing bolts		61900013 61900007	S10-PE30/2C PE55/2E-110/2E	
	<b>Fixed Coupling</b> (brass) GEKA with external thread	G 1¼"	15020003	S10-PE30/2C	
	<b>Hose Coupling</b> with nozzle, outer dia. 34 mm	G 1¼"	15020018	S10-PE30/2C	
<b>Horizontal</b> (tank connection)	<b>Pump</b> with built-in flange on suction side	DN 150/PN 16 to DIN 2633	On request	S10-PE110/2E	
	<b>Head Support</b> (EN-GJL-250) with vibration damping		62665103 41425005	S10-PE30/2C PE55/2E-110/2E	
<b>General</b>	<b>Non-return Valve</b> (EN-GJL-250) ball valve with internal thread	G1¼"	61400525	08-PE110/2E	
		G1½"	61400526		
		G2"	61400527		
	<b>Shut-off Valve</b> (brass) with internal thread	G1¼"	14040005	08-PE110/2E	
		G1½"	14040006		
		G2"	14040007		