

ABS ROBUSTA LIGHT DRAINAGE PUMP 1, 200 AND 300



The next generation of submersible pumps for clear and surface water for house and garden.

Available ready to plug in with built-in checkvalve.

ABS ROBUSTA 1 can pump down to 1mm.

ABS ROBUSTA 200 and 300 with built-in level control.

Applications

The ABS ROBUSTA series has been designed for pumping clear and wastewater from house, garden or yard, and is supplied with built-in level control and checkvalve. The pump and motor section form a pressure-tight encapsulated unit, with motor housing constructed from corrosion resistant material. The outer jacket and impeller are made of durable plastics. The unique hand /auto switch makes the pump suitable for manual or automatic operation. For applications with an aggressive medium we recommend the use of the IP 900.

The ABS ROBUSTA 1 is especially designed for pumping wastewater and drainage water in locations such as roofs where the level is low and almost all the water must be pumped away.

The pump has a special hydraulics which start pumping at a water level of 20 mm and pump away residual water to 1 mm. The actual level of the residual water may vary depending on factors such as surface texture and composition, evenness of surface etc.

As the pump is designed to pump down to 1 mm, it is not fitted with an automatic float system. The pump is switched off by unplugging it.

Construction

- Discharge outlet G1¼" with built-in checkvalve.
- Connection chamber with cover and watertight cable inlet and strain relief.
- Outer jacket and other housing parts made of corrosion resistant synthetic material. Motor housing is made of coated aluminium.
- Motor is dynamically balanced with temperature monitor in the stator, which switches off the pump in the case of over heating and switches on automatically after cooling down.
- Shaft is made of stainless steel.
- The sealing on the motor side is by means of special lip seals supported by lubricated bearings.
- The medium being pumped flows around the motor housing for optimum heat dissipation.
- The medium temperature is 40° C; intermittent usage to 60° C (max. 5 min).
- The TS version has a built-in automatic level control, with easily removable float cover for cleaning purposes.
- Integrated switch for continuous operation in transportable applications.
- The special bayonet clamping allows the screen to be removed by hand in the event an impeller inspection is necessary.



- The ABS ROBUSTA 1 pumps down to 1 mm
- The ABS ROBUSTA 200 and 300 is fitted with an automatic level control. For transportable applications, the Hand-Auto switch can be changed to continuous operation
- The ABS ROBUSTA is ready for immediate use. For transportable applications the hose nozzle, designed for two standard hose sizes, is ready for direct hose connection
- For emptying flooded cellars, for draining pits, sumps and for pumping rain water
- The checkvalve built into the discharge blocks return-flow from the discharge line when the pump is switched off
- Suitable even for small sumps (from 300 x 300 mm)
- Checkvalve included

Materials

Pump casing _____ Polypropylene
Motor shaft _____ 1.4021 (AISI 420)
Impeller _____ Polypropylene
Seals _____ Neoprene
Cable _____ Neoprene

ABS ROBUSTA LIGHT DRAINAGE PUMP 1, 200 AND 300

Technical Data

| | Discharge connection internal-thread | Solids size mm | Motor power* P ₁ kW | | Rated voltage V | Rated current A | Cable** | Cable length m | Level control | Weight kg |
|------------------|--------------------------------------|----------------|--------------------------------|--------------|-----------------|-----------------|--------------|----------------|---------------|-----------|
| ROBUSTA 1 | G 1 1/4" | 1 | 0.28 | Single phase | 220-240 ~ | 1.3 | H05RN-F3G1.0 | 10 | none | 3.0 |
| ROBUSTA 200 W/TS | G 1 1/4" | 10 | 0.46 | Single phase | 220-240 ~ | 2.1 | H07RN-F3G1.0 | 10/3*** | standard | 3.3 |
| ROBUSTA 300 W/TS | G 1 1/4" | 10 | 0.54 | Single phase | 220-240 ~ | 2.4 | H07RN-F3G1.0 | 10/3*** | standard | 3.8 |

*P₁ = Power taken from mains ** = with Euro-plug with earthing *** For external applications, the following VDE regulations apply: Submersible pumps for use externally must have a fixed cable connection with a length of at least 10 m. Regulations vary in other countries.

Performance Curves 50 Hz

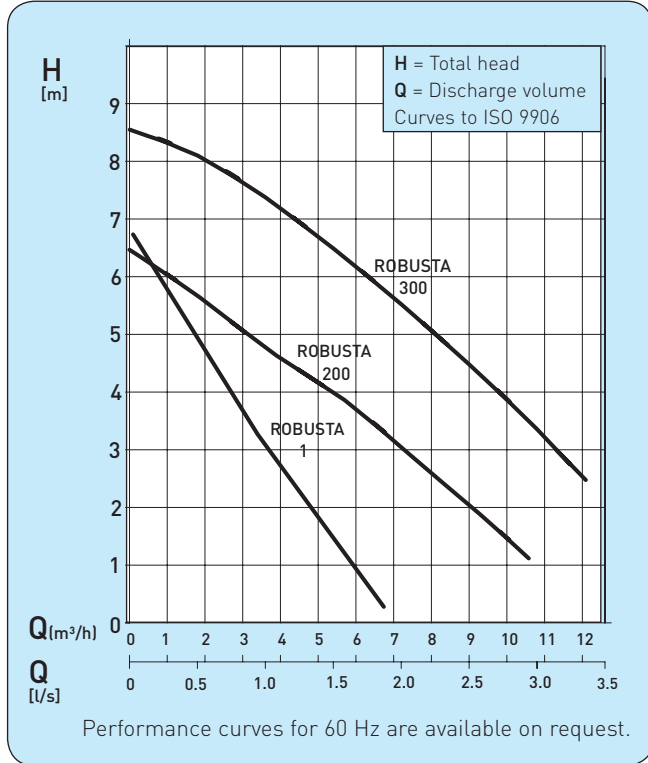

Dimensions

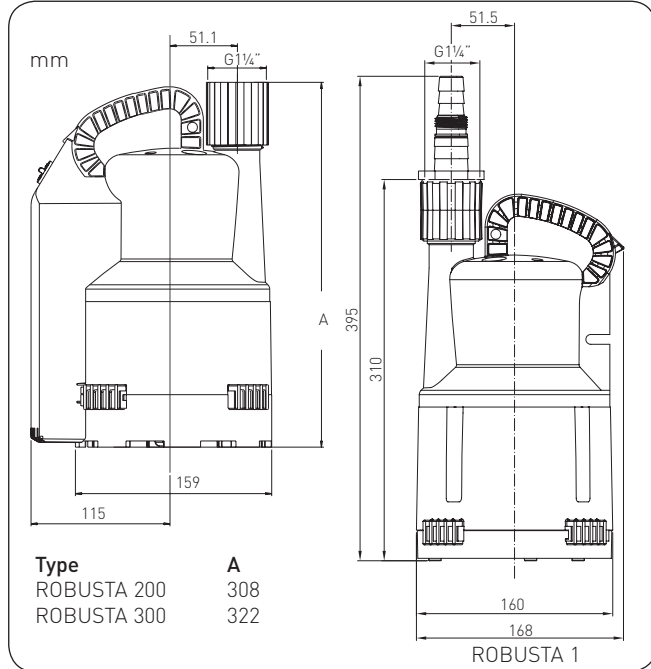

Installation

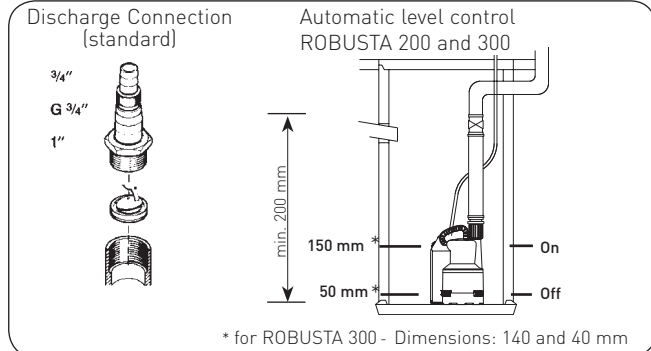

| Accessories (Material) | Size | Part No. |
|--|---------------------------|----------|
| <input type="checkbox"/> Control unit | | |
| for double pumping station, with automatic changing of the start sequence, alarm and potential-free fault indicator also: | | |
| 2 level control units | KS 5 = 5 m cable or KS 10 | |
| 1 alarm contact float | KS 5 = 5 m cable or KS 10 | |
| <input type="checkbox"/> Plug in alarm for DIN type socket 230 V | | 16020201 |
| with audible alarm, alarm diode and cancel button potential-free fault output, mains-operated, however, supplied with loading unit for mains independent operating | | |
| NC-batteries | | 12820018 |
| 9VTR 7-8, for mains independent operating | | |
| Alarm contact float | KS 5 = 5 m | 62450016 |
| with ABS float switch | KS 10 = 10 m | 62450017 |
| <input type="checkbox"/> Check valve (synthetic) | G 1 1/4" | 61400511 |
| with internal thread, PA-1-3082 | | |
| <input type="checkbox"/> Gate valve (brass) | G 1 1/4" | 14040005 |
| with internal thread | | |
| <input type="checkbox"/> Discharge hose (PVC) | 3/4" m | 15060016 |
| | 1" m | 15060007 |
| | 1 1/4" m | 15060008 |

| Accessories (Material) | Size | Part No. |
|---|---------------|----------|
| <input type="checkbox"/> Fixed coupling (brass) | GEKA G 1 1/4" | 15020008 |
| with internal thread | | |
| <input type="checkbox"/> Fixed coupling (brass) | GEKA G 1 1/4" | 15020003 |
| with external thread | | |
| <input type="checkbox"/> Hose coupling (brass) | GEKA 3/4" | 15020016 |
| | 1" | 15020017 |
| | 1 1/4" | 15020018 |
| <input type="checkbox"/> Hose coupling (steel, galv.) | 3/4" | 15070002 |
| | 1" | 15070003 |
| | 1 1/4" | 15070004 |

