

world novelty!
Automatic low suction
by level sensor!

Low Suction Pump with Automatic Level Sensor for Flood Protection

Chromatic® C 237 WF

Application

Automatic drainage at low water level from 5 mm to prevent flooding in rooms without pump pit or floor drain, e. g. by flood water, rain, defective water pipe or defective washing machine. The level sensor starts the pump automatically at a water level of 5 mm and pumps down to 2 mm remaining level. The water jacket cooled motor with the top discharge protects the motor against overheating even during sip operation.

Installation: Permanent or transportable.

Pumped medium: Clear water or drainage water containing soft solids with a maximum diameter of 4 mm. Max. medium temperature: 35°C, short term up to 60°C.

Operation: Intermittent.

Design

Fully submersible drainage pump consisting of:

Pump: Single stage centrifugal pump with vertical discharge BSP 1" M.

Impeller: Open multi-channel impeller, spherical clearance 4 mm.

Motor: Fully submersible, pressure tight electric motor. Stainless steel motor housing. Insulation class B. Motor protection IP 68. Thermal sensors imbedded in the motor winding.

Shaft/bearing: Large diameter stainless steel rotor shaft, pre-lubricated bearings.

Seals: Triple lip-seal combination.

Protected by german patent.

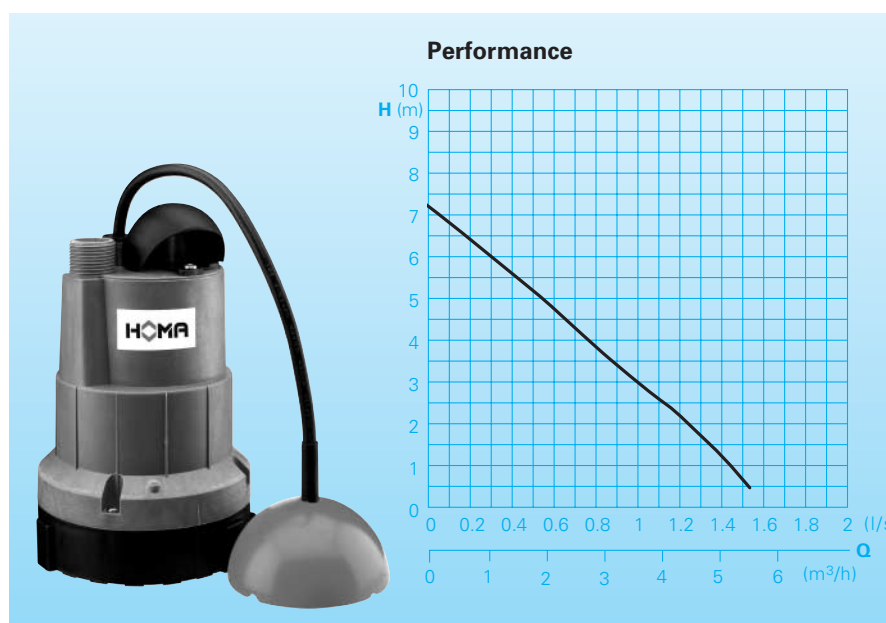

Technical Data

Pump type	Motor-input P ₁ (kW)	Motor-output P ₂ (kW)	Voltage 50 Hz (V)	Nominal current (A)	Cable type	Weight (kg)
C 237 WF	0,27	0,2	230/1ph	1,5	H05RN-F	4,2

Speed: 2900 rpm

Discharge: BSP 1" M

Materials:

Motor housing, motor shaft, screws	Stainless steel
Suction sieve, Pump housing	Wear resistant synthetic material (composite)
Impeller, pressure cover	Glass-fibre, reinforced synthetic material (composite)
Elastomere	NBR

Equipment supplied

Pump with level sensor, 10 m of cable and plug.

Dimensions and Installation

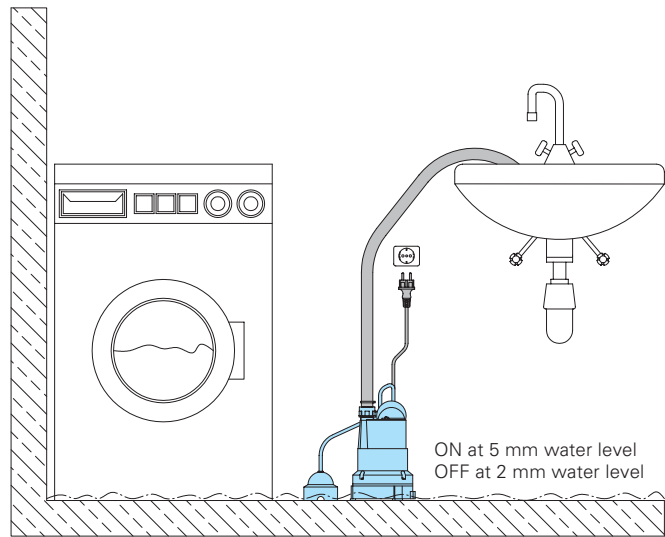
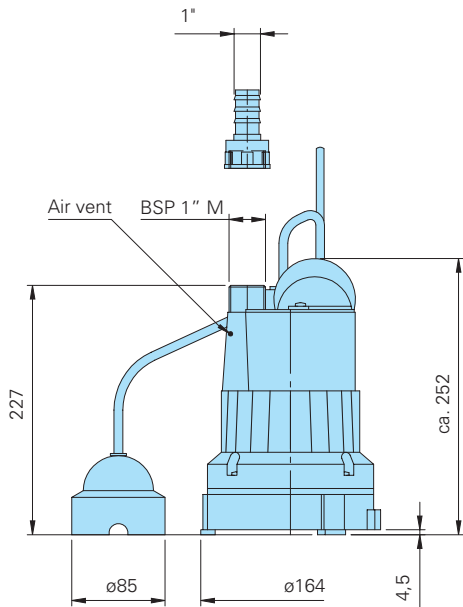

all dimensions in mm

Accessories

Part Description	Dimension	Part. No.
① Brass hose coupling	BSP 1"	2003313
② PVC hose, per m	1" Ø	2621000
Reinforced hose, per m	1" Ø	2632025
Hose band	3/4" - 1"	2302330
○ HOMA 2 poles earth leakage circuit breaker		1586010
	Fi 16/0,03 A	

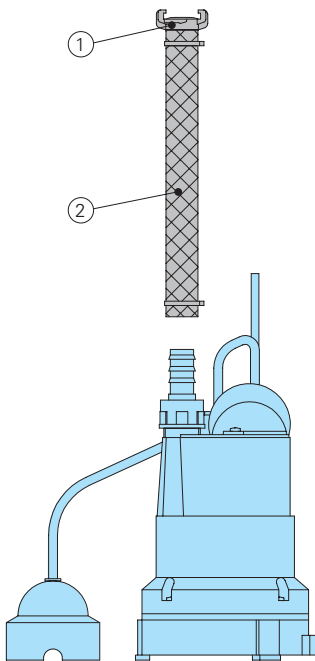

HOMA
P U M P T E C H N O L O G Y

HOMA Pumpenfabrik GmbH
P.O. Box 22 63, D-53814 Neunk.-Seelscheid
Tel. +49(0)22 47/702-0, Fax +49(0)22 47/702-44
e-mail: info@homa-pumpen.de
www.homapumps.com