

Series description Wilo-TOP-S

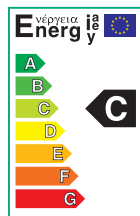

> Note

EEL classification for each pump type, see Chapter: "Planning guide"

Design

Glandless circulation pump with screwed connection or flange connection. Preselectable speed stages for power adjustment.

Application

Hot-water heating systems of all kinds, industrial circulation systems, air-conditioning systems and closed cooling circuits

Type key

| | |
|--------------|---|
| Example: | TOP-S 40/10 |
| TOP-S | Standard pump (screw-end or flange-end pump) |
| 40/ | Nominal connection diameter |
| 10 | Nominal delivery head range [m] at $Q = 0 \text{ m}^3/\text{h}$ |

Options

- Special version for operating pressure PN 16 (at additional charge)
- Version for special voltages on request.

Special features/product benefits

- Can be used in heating systems and in cooling/air-conditioning systems from $-20 \text{ }^\circ\text{C}$ to $+130 \text{ }^\circ\text{C}$
- Manual power adjustment with 2 speed stages (for pumps 1~230 V with $P_2 \geq 350 \text{ W}$) or with 3 speed stages
- Pump housing with cathaphoretic (KTL) coating for the prevention of corrosion by condensation formation
- With thermal insulation as standard
- Simple installation due to combination flange PN 6/PN 10 (for DN 40 to DN 65)
- Cable feed in to terminal box possible on both sides (from $P_2 \geq 180 \text{ W}$) with integrated strain relief device
- Protection class IP 44

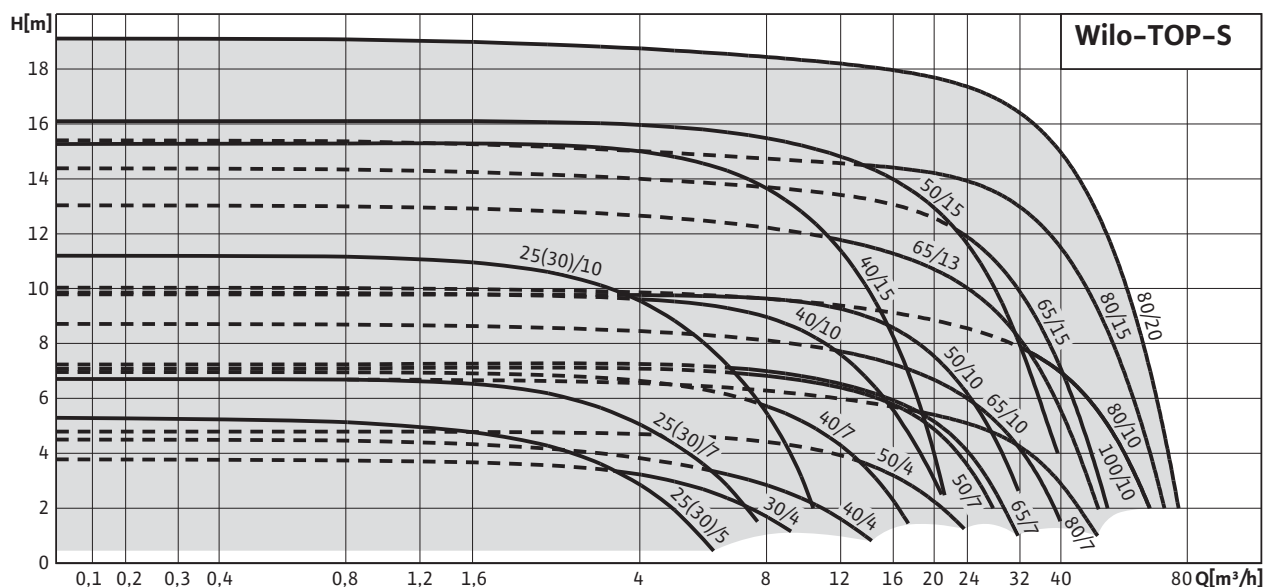

Heating, air-conditioning, cooling

Standard pumps (single pumps)

Series description Wilo-TOP-S

Equipment/function

Operating modes

- Speed-stage switching

Manual functions

- Setting the speed stages: 3 speed stages (2 speed stages for 1~pumps with $P_2 \geq 350$ W)

Automatic functions

- Full motor protection with integrated trip electronics (standard equipment only for 3~pumps with $P_2 \geq 180$ W and 1~pumps with $P_2 \geq 350$ W, optional for all types with Wilo-Protect-Module C)

External control functions

- "Overriding Off" control input (optional for all types with Wilo-Protect-Module C)

Signal and display functions

- Individual/collective fault signal (potential-free NC contact) (optional for all types with Wilo-Protect-Module C) collective fault signal (potential-free NC contact) (standard equipment only for 3~pumps with $P_2 \geq 180$ W and 1~pumps with $P_2 \geq 350$ W, optional for all types with Wilo-Protect-Module C)
- Individual run signal (potential-free NO contact) (optional for all types with Wilo-Protect-Module C)
- Thermal winding contact (WSK, potential-free NC contact) (only for 1~pumps with $P_2 = 180$ W)
- Fault signal light (standard equipment only for 3~pumps with $P_2 \geq 180$ W and 1~pumps with $P_2 \geq 350$ W, optional for all types with Wilo-Protect-Module C)
- Direction-of-rotation control light

Dual pump management (double pump or 2 x single pump)

- Main/standby mode (automatic fault-actuated switchover/time-dependent pump cycling): optional for all types with Wilo-Protect-Module C

Equipment

- Cable lead-in possible from both sides (only for 1~pumps and 3~pumps with $P_2 \geq 180$ W)

Scope of delivery

- Pump
- Thermal insulation
- Including seals for threaded connection
- Washers for flange screws (for nominal connection diameters DN 40 – DN 65)
- Installation and operating instructions

Accessories

- Screwed connections with screw thread
- For pumps 3~400 V:
 - Switching plug 3~230 V, 50 Hz
 - Wilo-Protect-Module C, 3~400 V
- For pumps 1~230 V:
 - Wilo-SK 602/SK 622 tripping unit for full motor protection
 - Wilo-Protect-Module C, 1~230 V
- Pump cold water insulation Wilo KlimaForm

Technical data Wilo-TOP-S

| | Wilo-TOP-S ... | | | | | | | |
|---|---|------|-------|---|------|---|------|-------|
| | 25/5 | 25/7 | 25/10 | 25/13 | 30/4 | 30/5 | 30/7 | 30/10 |
| Approved fluids (other fluids on request) | | | | | | | | |
| Heating water (in accordance with VDI 2035) | • | • | • | • | • | • | • | • |
| Water-glycol mixtures (max. 1:1; above 20% admixture, the pumping data must be checked) | • | • | • | • | • | • | • | • |
| Potable water and water for food-processing companies in accordance with TrinkwV 2001 (drinking water ordinance) | - | - | - | - | - | - | - | - |
| Output | | | | | | | | |
| Delivery head max. [m] | 5 | 7 | 11.5 | 13 | 4 | 5 | 7 | 11.5 |
| Max. volume flow [m ³ /h] | 5 | 7.5 | 10.3 | 4 | 9 | 5 | 7.5 | 10 |
| Permitted field of application | | | | | | | | |
| Temperature range for applications in heating/ventilation/air-conditioning systems at max. ambient temperature of +25 °C [°C] | - | | | | | | | |
| Temperature range for applications in heating, ventilation & air-conditioning systems at max. ambient temperature of +40 °C | -20 up to +130 (in short-term operation 2 h: +140) (for applications with Wilo-Protect-Module C: -20 to +110) | | | -20 up to +110 (in short-term operation 2 h: +140) (for applications with Wilo-Protect-Module C: -20 to +110) | | -20 up to +130 (in short-term operation 2 h: +140) (for applications with Wilo-Protect-Module C: -20 to +110) | | |
| Temperature range for applications in secondary hot water circulation systems at max. ambient temperature of +40 °C [°C] | - | - | - | - | - | - | - | - |
| Maximum permissible total hardness in secondary hot water circulation systems [°d] | - | - | - | - | - | - | - | - |
| Standard version for operating pressure, p _{max} | 10 | 10 | 10 | 10 | 10 | 10 | 10 | 10 |
| Special version for operating pressure, p _{max} | - | - | 16 | - | - | - | - | 16 |
| Pipe connections | | | | | | | | |
| Screwed connection Rp | 1 | 1 | 1 | 1 | 1¼ | 1¼ | 1¼ | 1¼ |
| Nominal flange diameter DN | - | - | - | - | - | - | - | - |
| Flange for counter flange PN 6, standard version | - | - | - | - | - | - | - | - |
| Flange for counter flange PN 16, special version | - | - | - | - | - | - | - | - |
| Combination flange PN 6/10 for counter flanges PN 6 and PN 16, standard version | - | - | - | - | - | - | - | - |
| Support-bracket mounting (with horizontal shaft only), standard version | - | - | - | - | - | - | - | - |
| Support-bracket mounting (with horizontal shaft only), special version | - | - | - | - | - | - | - | - |

Heating, air-conditioning, cooling

Standard pumps (single pumps)

Technical data Wilo-TOP-S

| | Wilo-TOP-S ... | | | | | | | |
|--|----------------------------------|-----------------------|----------------------------------|-------|-------|-----------------------|-------|-------|
| | 25/5 | 25/7 | 25/10 | 25/13 | 30/4 | 30/5 | 30/7 | 30/10 |
| Electrical connection | | | | | | | | |
| Mains connection 1 ~ [V], standard version | 230 | 230 | 230 | 230 | 230 | 230 | 230 | 230 |
| Mains connection 3 ~ [V], standard version | 400 | 400 | 400 | 400 | 400 | 400 | 400 | 400 |
| Mains connection 3 ~ [V], with optional switching plug | 230 | 230 | 230 | 230 | 230 | 230 | 230 | 230 |
| Mains frequency | 50 | 50 | 50 | 50 | 50 | 50 | 50 | 50 |
| Motor/electronics | | | | | | | | |
| Electromagnetic compatibility | - | | | | | | | |
| Emitted interference | EN 61000-6-3 | | | | | | | |
| Interference resistance | EN 61000-6-2 | | | | | | | |
| Power electronics | - | - | - | - | - | - | - | - |
| Protection class | IP 44 | IP 44 | IP 44 | IP 44 | IP 44 | IP 44 | IP 44 | IP 44 |
| Insulation class | H | H | H | H | H | H | H | H |
| Materials | | | | | | | | |
| Pump housing | Grey cast iron (EN-GJL-200) | | | | | | | |
| Impeller | Plastic (PPE), trade name: Noryl | Plastic (PP - 50% GF) | Plastic (PPE), trade name: Noryl | | | Plastic (PP - 50% GF) | | |
| Pump shaft | Stainless steel (X46Cr13) | | | | | | | |
| Bearing | Carbon, metal impregnated | | | | | | | |
| Minimum suction head at suction port [m] for preventing cavitation at water pumping temperature | | | | | | | | |
| Minimum suction head at 50°C | 0.5 | 0.5 | 0.5 | 0.5 | 0.5 | 0.5 | 0.5 | 0.5 |
| Minimum suction head at 95°C | 5 | 5 | 5 | 5 | 5 | 5 | 5 | 5 |
| Minimum suction head at 110°C | 11 | 11 | 11 | 11 | 11 | 11 | 11 | 11 |
| Minimum suction head at 130°C | 24 | 24 | 24 | - | 24 | 24 | 24 | 24 |

• = available, - = not available

Technical data Wilo-TOP-S

| | Wilo-TOP-S ... | | | | | | | | | |
|---|--|------|-------|-------|------|------|-------|-------|------|-------|
| | 40/4 | 40/7 | 40/10 | 40/15 | 50/4 | 50/7 | 50/10 | 50/15 | 65/7 | 65/10 |
| Approved fluids (other fluids on request) | | | | | | | | | | |
| Heating water (in accordance with VDI 2035) | • | • | • | • | • | • | • | • | • | • |
| Water-glycol mixtures (max. 1:1; above 20% admixture, the pumping data must be checked) | • | • | • | • | • | • | • | • | • | • |
| Potable water and water for food-processing companies in accordance with TrinkwV 2001 (drinking water ordinance) | - | - | - | - | - | - | - | - | - | - |
| Output | | | | | | | | | | |
| Delivery head max. [m] | 4.5 | 7 | 10 | 15 | 5 | 7 | 10 | 16 | 7 | 8 |
| Max. volume flow [m ³ /h] | 14 | 16.5 | 21 | 21 | 23 | 28 | 32 | 39 | 32 | 40 |
| Permitted field of application | | | | | | | | | | |
| Temperature range for applications in heating/ventilation/air-conditioning systems at max. ambient temperature of +25 °C [°C] | - | | | | | | | | | |
| Temperature range for applications in heating, ventilation & air-conditioning systems at max. ambient temperature of +40 °C | -20 up to +130 (in short-term operation 2 h: +140) (for applications with Wilo-Protect-Module C: -20 to +110) | | | | | | | | | |
| Temperature range for applications in secondary hot water circulation systems at max. ambient temperature of +40 °C [°C] | - | - | - | - | - | - | - | - | - | - |
| Maximum permissible total hardness in secondary hot water circulation systems [°d] | - | - | - | - | - | - | - | - | - | - |
| Standard version for operating pressure, p _{max} | 6/10 | 6/10 | 6/10 | 6/10 | 6/10 | 6/10 | 6/10 | 6/10 | 6/10 | 6/10 |
| Special version for operating pressure, p _{max} | 16 | 16 | 16 | 16 | 16 | 16 | 16 | 16 | 16 | 16 |
| Pipe connections | | | | | | | | | | |
| Screwed connection Rp | - | - | - | - | - | - | - | - | - | - |
| Nominal flange diameter DN | 40 | 40 | 40 | 40 | 50 | 50 | 50 | 50 | 65 | 65 |
| Flange for counter flange PN 6, standard version | - | - | - | - | - | - | - | - | - | - |
| Flange for counter flange PN 16, special version | • | • | • | • | • | • | • | • | • | • |
| Combination flange PN 6/10 for counter flanges PN 6 and PN 16, standard version | • | • | • | • | • | • | • | • | • | • |
| Support-bracket mounting (with horizontal shaft only), standard version | - | - | - | - | - | - | - | - | - | - |
| Support-bracket mounting (with horizontal shaft only), special version | • | • | • | • | • | • | • | • | • | • |
| Electrical connection | | | | | | | | | | |
| Mains connection 1 ~ [V], standard version | 230 | 230 | - | - | 230 | - | - | - | - | - |
| Mains connection 3 ~ [V], standard version | 400 | 400 | 400 | 400 | 400 | 400 | 400 | 400 | 400 | 400 |
| Mains connection 3 ~ [V], with optional switching plug | 230 | 230 | 230 | 230 | 230 | 230 | 230 | 230 | 230 | 230 |
| Mains frequency | 50 | 50 | 50 | 50 | 50 | 50 | 50 | 50 | 50 | 50 |

Heating, air-conditioning, cooling

Standard pumps (single pumps)

Technical data Wilo-TOP-S

| | Wilo-TOP-S ... | | | | | | | | | |
|--|-----------------------------|-------|-------|-------|-------|-------|-------|-------|-------|-------|
| | 40/4 | 40/7 | 40/10 | 40/15 | 50/4 | 50/7 | 50/10 | 50/15 | 65/7 | 65/10 |
| Motor/electronics | | | | | | | | | | |
| Electromagnetic compatibility | - | | | | | | | | | |
| Emitted interference | EN 61000-6-3 | | | | | | | | | |
| Interference resistance | EN 61000-6-2 | | | | | | | | | |
| Power electronics | - | - | - | - | - | - | - | - | - | - |
| Protection class | IP 44 | IP 44 | IP 44 | IP 44 | IP 44 | IP 44 | IP 44 | IP 44 | IP 44 | IP 44 |
| Insulation class | H | H | H | H | H | H | H | H | H | H |
| Materials | | | | | | | | | | |
| Pump housing | Grey cast iron (EN-GJL-250) | | | | | | | | | |
| Impeller | Plastic (PP - 50% GF) | | | | | | | | | |
| Pump shaft | Stainless steel (X46Cr13) | | | | | | | | | |
| Bearing | Carbon, metal impregnated | | | | | | | | | |
| Minimum suction head at suction port [m] for preventing cavitation at water pumping temperature | | | | | | | | | | |
| Minimum suction head at 50°C | 0.5 | 0.5 | 0.5 | 3.0 | 3.0 | 3.0 | 3.0 | 3.0 | 3.0 | 3.0 |
| Minimum suction head at 95°C | 5 | 5 | 5 | 10 | 10 | 10 | 10 | 10 | 10 | 10 |
| Minimum suction head at 110°C | 11 | 11 | 11 | 16 | 16 | 16 | 16 | 16 | 16 | 16 |
| Minimum suction head at 130°C | 24 | 24 | 24 | 29 | 29 | 29 | 29 | 29 | 29 | 29 |

• = available, - = not available

Technical data Wilo-TOP-S

| | Wilo-TOP-S ... | | | | | | |
|---|--|-------|-------|-------|----------------|-------|--|
| | 65/13 | 65/15 | 80/7 | 80/10 | 80/15 | 80/20 | 100/10 |
| Approved fluids (other fluids on request) | | | | | | | |
| Heating water (in accordance with VDI 2035) | • | • | • | • | • | • | • |
| Water-glycol mixtures (max. 1:1; above 20% admixture, the pumping data must be checked) | • | • | • | • | • | • | • |
| Potable water and water for food-processing companies in accordance with TrinkwV 2001 (drinking water ordinance) | - | - | - | - | - | - | - |
| Output | | | | | | | |
| Delivery head max. [m] | 13 | 15 | 7 | 10 | 15.5 | 19 | 10 |
| Max. volume flow [m ³ /h] | 49 | 52 | 49 | 65 | 70 | 76.5 | 65 |
| Permitted field of application | | | | | | | |
| Temperature range for applications in heating/ventilation/air-conditioning systems at max. ambient temperature of +25 °C [°C] | - | | | | | | |
| Temperature range for applications in heating, ventilation & air-conditioning systems at max. ambient temperature of +40 °C | -20 up to +130 (in short-term operation 2 h: +140) (for applications with Wilo-Protect-Module C: -20 to +110) | | | | -20 up to +110 | | -20 up to +130 (in short-term operation 2 h: +140) (for applications with Wilo-Protect-Module C: -20 to +110) |
| Temperature range for applications in secondary hot water circulation systems at max. ambient temperature of +40 °C [°C] | - | - | - | - | - | - | - |
| Maximum permissible total hardness in secondary hot water circulation systems [°d] | - | - | - | - | - | - | - |
| Standard version for operating pressure, p _{max} | 6/10 | 6/10 | 6 | 6 | 6 | 6 | 6 |
| Special version for operating pressure, p _{max} | 16 | 16 | 10/16 | 10/16 | 10/16 | 10/16 | 10/16 |
| Pipe connections | | | | | | | |
| Screwed connection Rp | - | - | - | - | - | - | - |
| Nominal flange diameter DN | 65 | 65 | 80 | 80 | 80 | 80 | 100 |
| Flange for counter flange PN 6, standard version | - | - | • | • | • | • | • |
| Flange for counter flange PN 16, special version | • | • | • | • | • | • | • |
| Combination flange PN 6/10 for counter flanges PN 6 and PN 16, standard version | • | • | - | - | - | - | - |
| Support-bracket mounting (with horizontal shaft only), standard version | - | - | - | - | - | - | - |
| Support-bracket mounting (with horizontal shaft only), special version | • | • | • | • | • | • | • |

Heating, air-conditioning, cooling

Standard pumps (single pumps)

Technical data Wilo-TOP-S

| | Wilo-TOP-S ... | | | | | | |
|--|-----------------------------|-------|-------|-------|-------|-------|--------|
| | 65/13 | 65/15 | 80/7 | 80/10 | 80/15 | 80/20 | 100/10 |
| Electrical connection | | | | | | | |
| Mains connection 1 ~ [V], standard version | - | - | - | - | - | - | - |
| Mains connection 3 ~ [V], standard version | 400 | 400 | 400 | 400 | 400 | 400 | 400 |
| Mains connection 3 ~ [V], with optional switching plug | 230 | 230 | 230 | 230 | - | - | 230 |
| Mains frequency | 50 | 50 | 50 | 50 | 50 | 50 | 50 |
| Motor/electronics | | | | | | | |
| Electromagnetic compatibility | - | | | | | | |
| Emitted interference | EN 61000-6-3 | | | | | | |
| Interference resistance | EN 61000-6-2 | | | | | | |
| Power electronics | - | - | - | - | - | - | - |
| Protection class | IP 44 | IP 44 | IP 44 | IP 44 | IP 44 | IP 44 | IP 44 |
| Insulation class | H | H | H | H | H | H | H |
| Materials | | | | | | | |
| Pump housing | Grey cast iron (EN-GJL-250) | | | | | | |
| Impeller | Plastic (PP - 50% GF) | | | | | | |
| Pump shaft | Stainless steel (X46Cr13) | | | | | | |
| Bearing | Carbon, metal impregnated | | | | | | |
| Minimum suction head at suction port [m] for preventing cavitation at water pumping temperature | | | | | | | |
| Minimum suction head at 50°C | 3.0 | 3.0 | 3.0 | 3.0 | 9.0 | 9.0 | 3.0 |
| Minimum suction head at 95°C | 10 | 10 | 10 | 10 | 18 | 18 | 10 |
| Minimum suction head at 110°C | 16 | 16 | 16 | 16 | 23 | 23 | 16 |
| Minimum suction head at 130°C | 29 | 29 | 29 | 29 | 36 | 36 | 29 |

• = available, - = not available

Pump curves Wilo-TOP-S

Wilo-TOP-S 25/5, 30/5

Alternating current

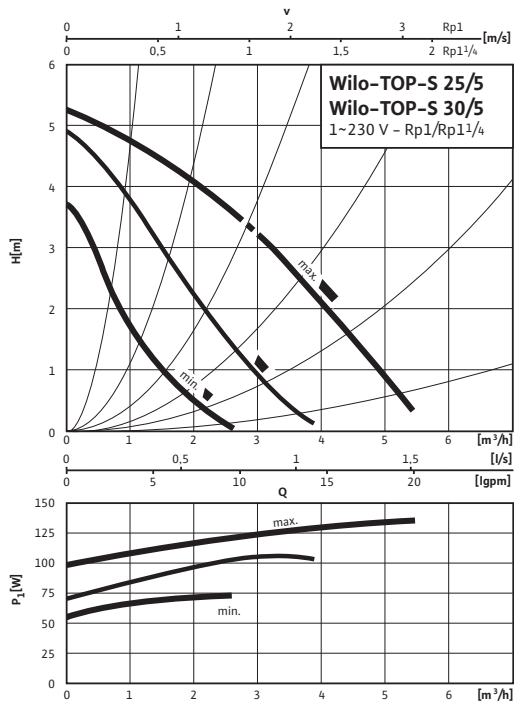

Three-phase current

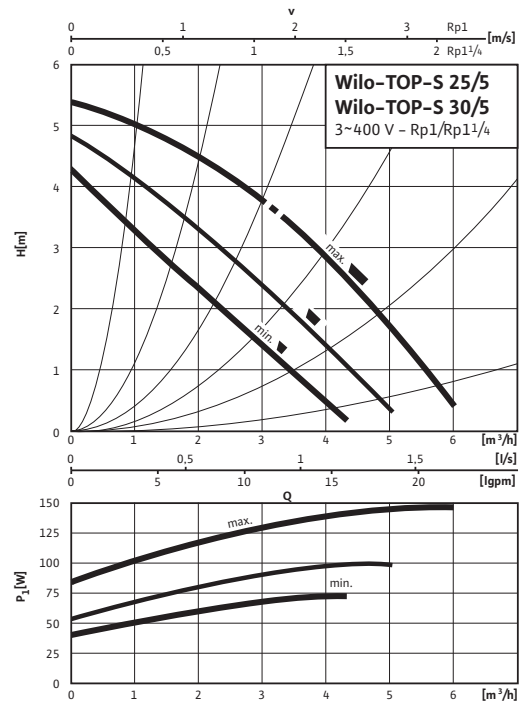

Wilo-TOP-S 25/7, 30/7

Alternating current

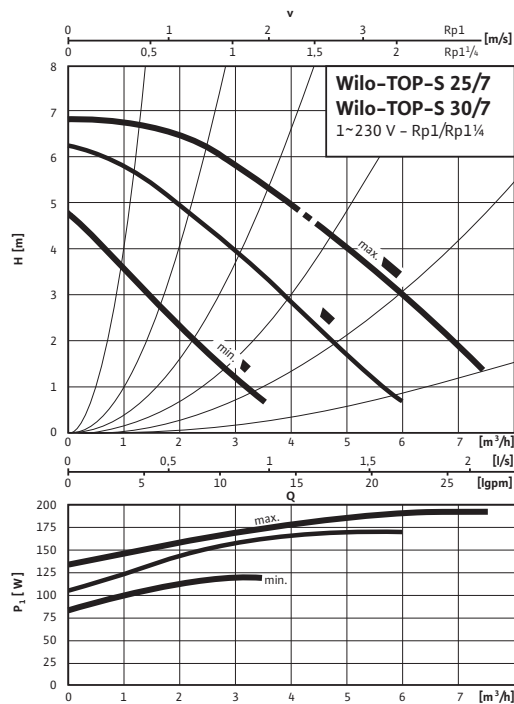

Three-phase current

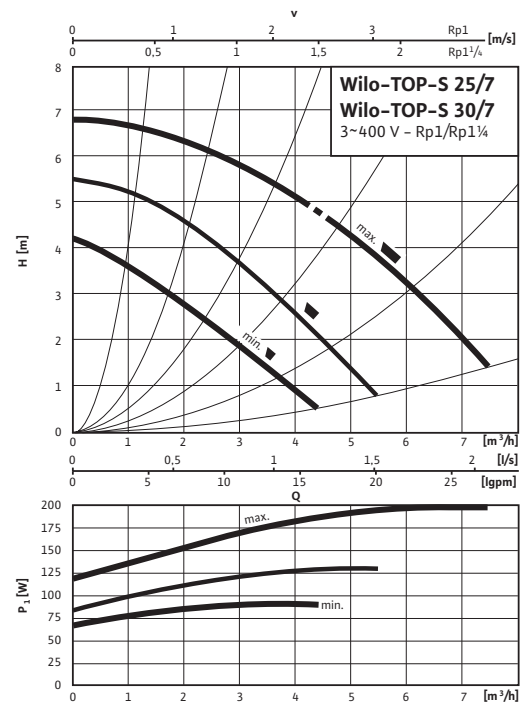

Heating, air-conditioning, cooling

Standard pumps (single pumps)

Pump curves Wilo-TOP-S

Wilo-TOP-S 25/10, 30/10

Alternating current

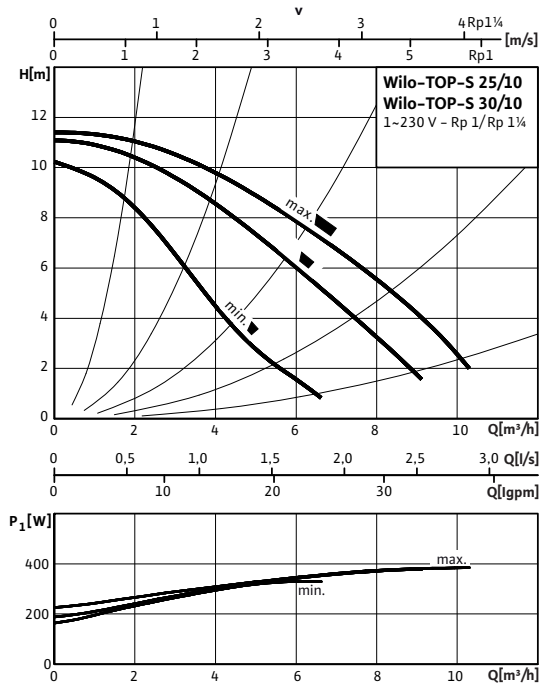

Three-phase current

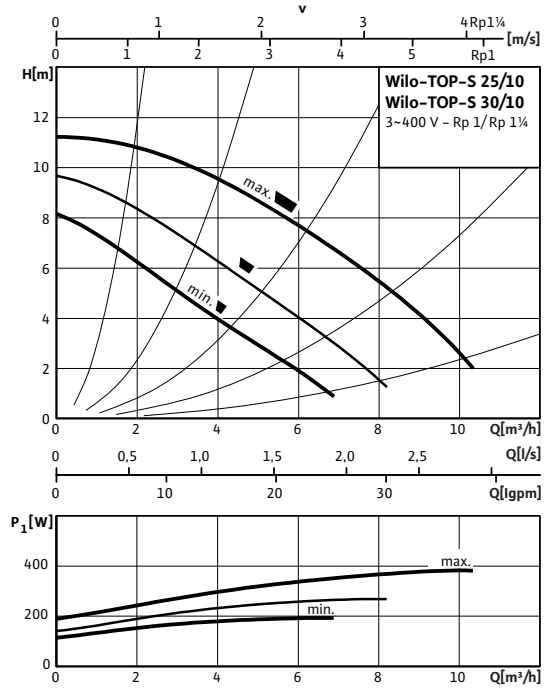

Wilo-TOP-S 25/13

Alternating current

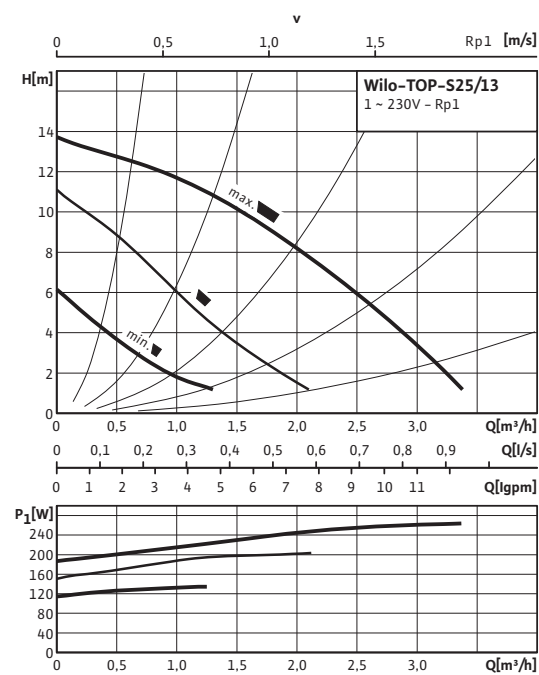

Three-phase current

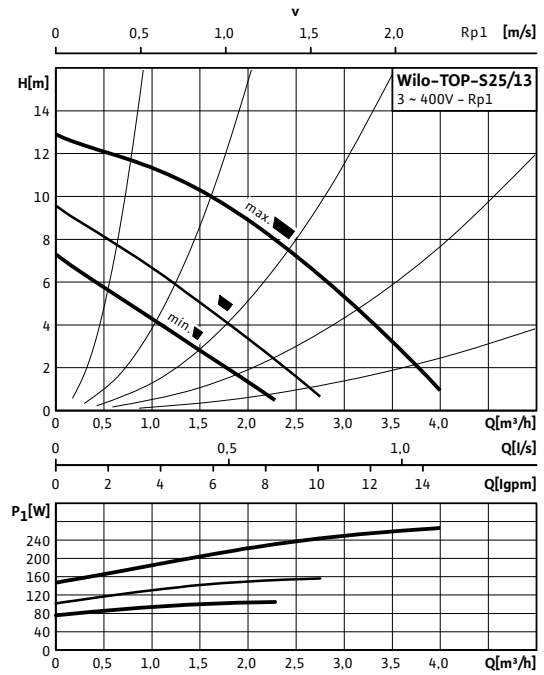

Pump curves Wilo-TOP-S

Wilo-TOP-S 30/4

Alternating current

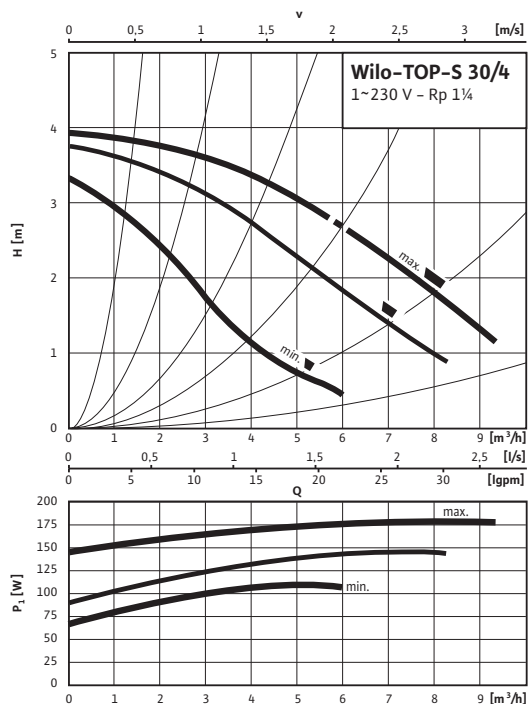

Three-phase current

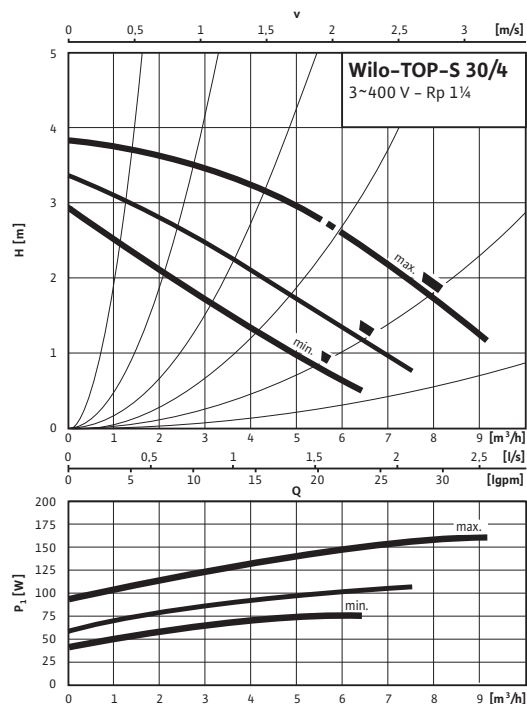

Wilo-TOP-S 40/4

Alternating current

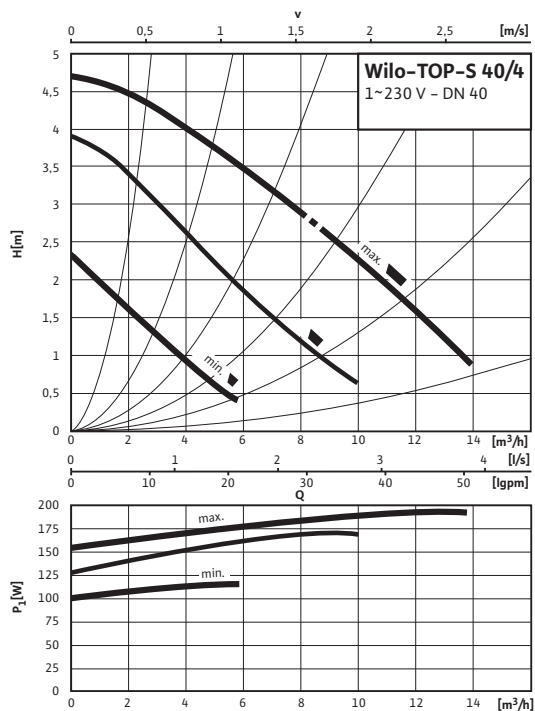

Three-phase current

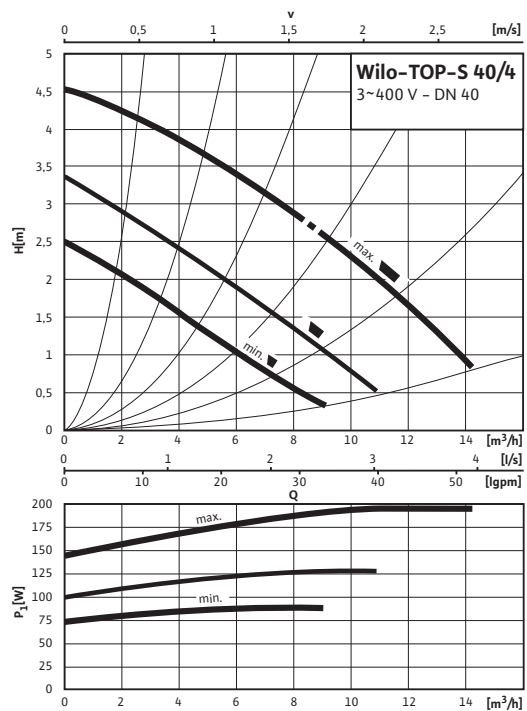

Heating, air-conditioning, cooling

Standard pumps (single pumps)

Pump curves Wilo-TOP-S

Wilo-TOP-S 40/7

Alternating current

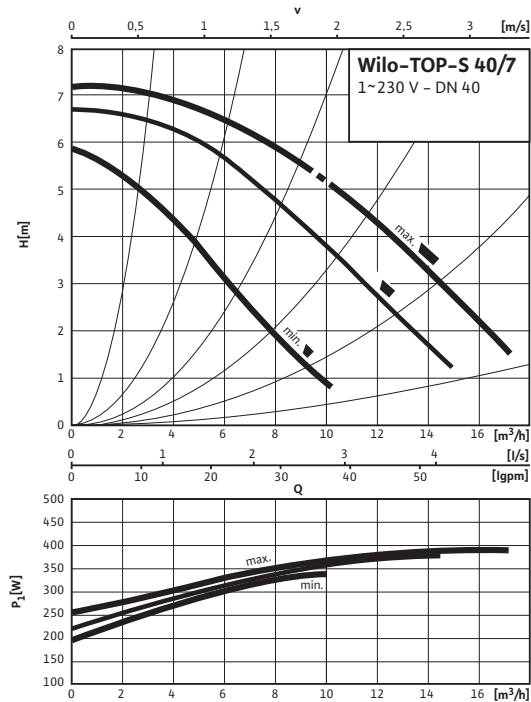

Three-phase current

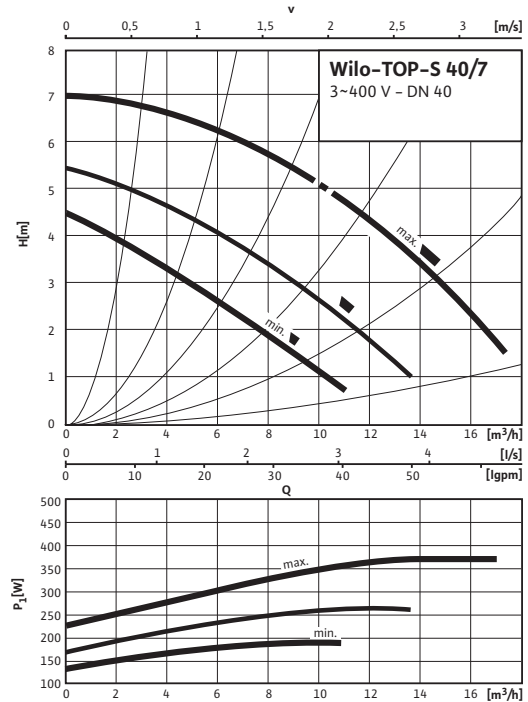

Wilo-TOP-S 40/10

Alternating current

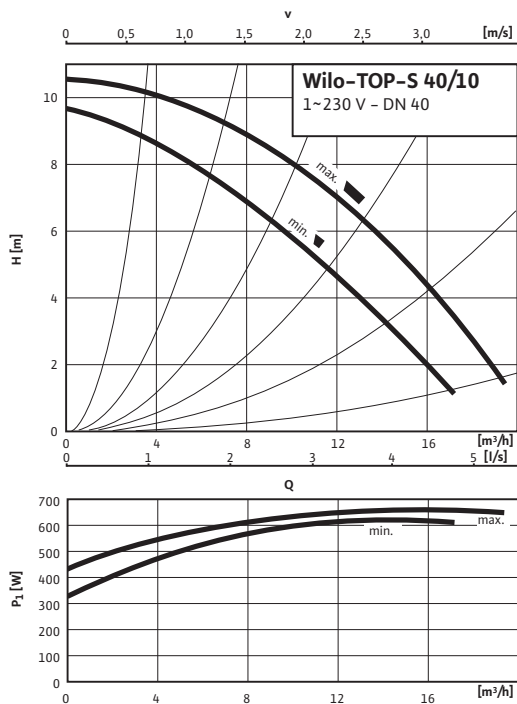

Three-phase current

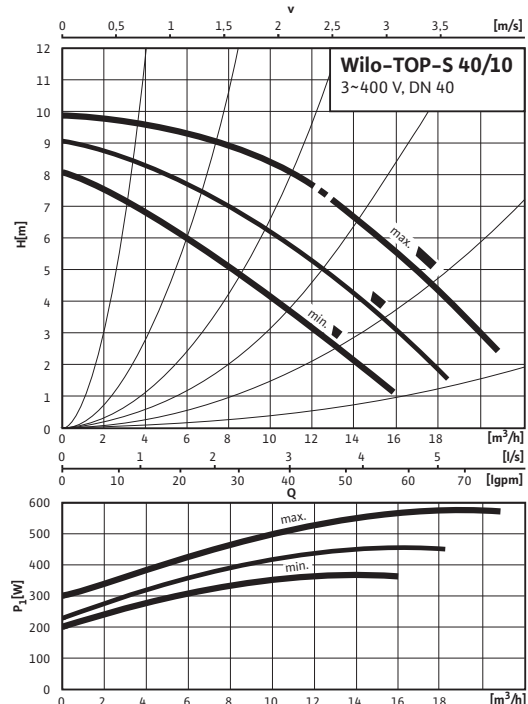

Pump curves Wilo-TOP-S

Wilo-TOP-S 40/15

Alternating current

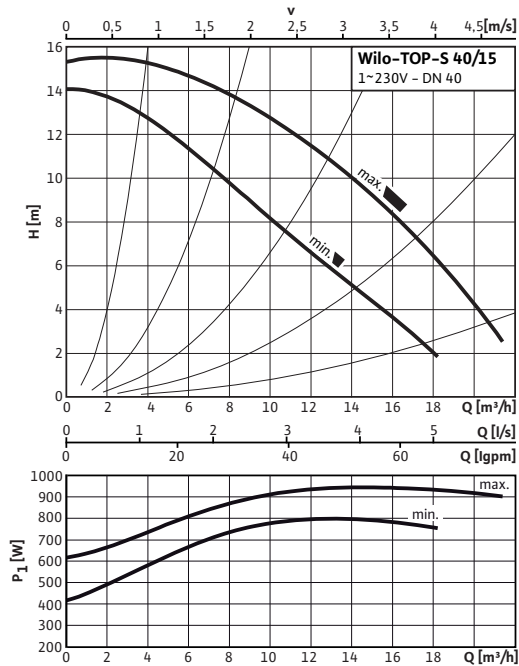

Three-phase current

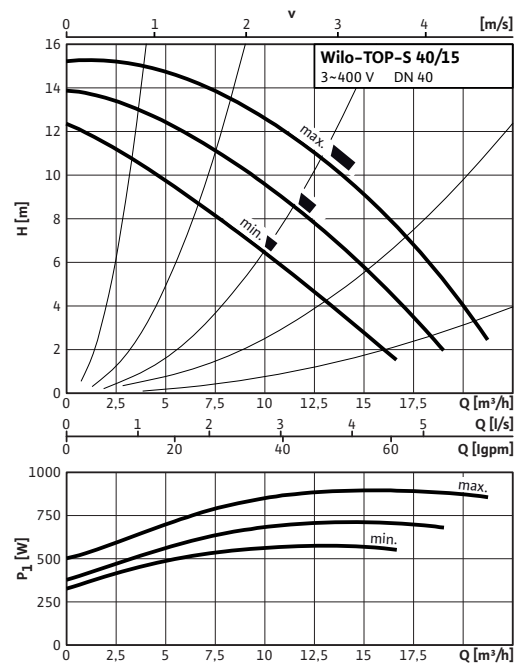

Wilo-TOP-S 50/4

Alternating current

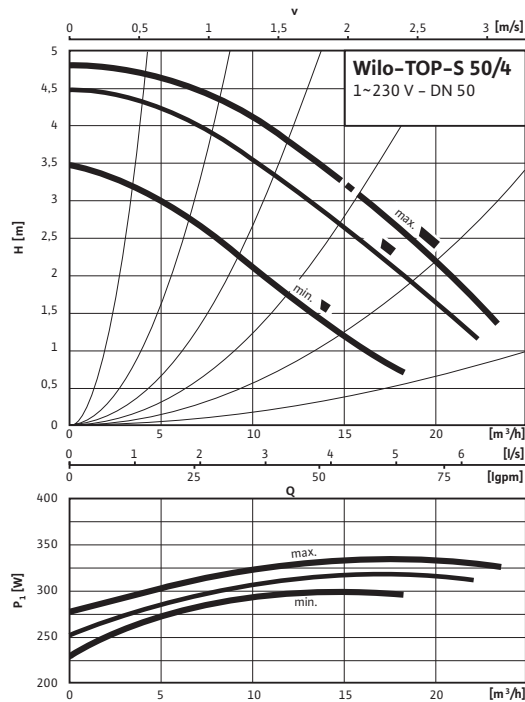

Three-phase current

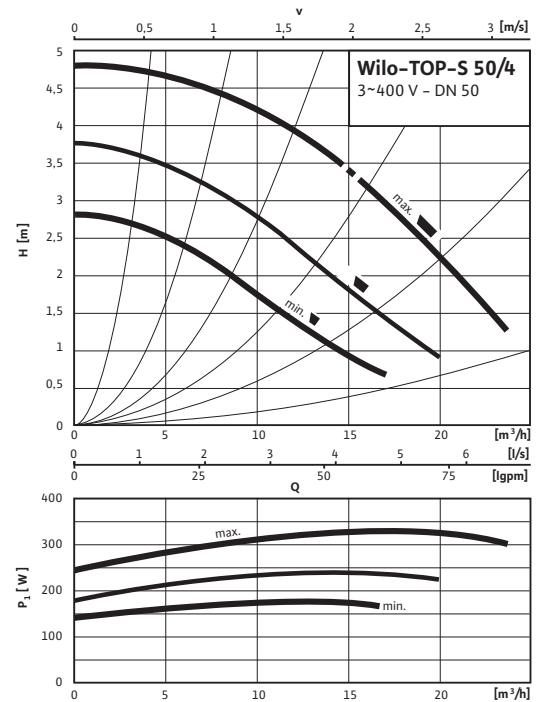

Heating, air-conditioning, cooling

Standard pumps (single pumps)

Pump curves Wilo-TOP-S

Wilo-TOP-S 50/7

Alternating current

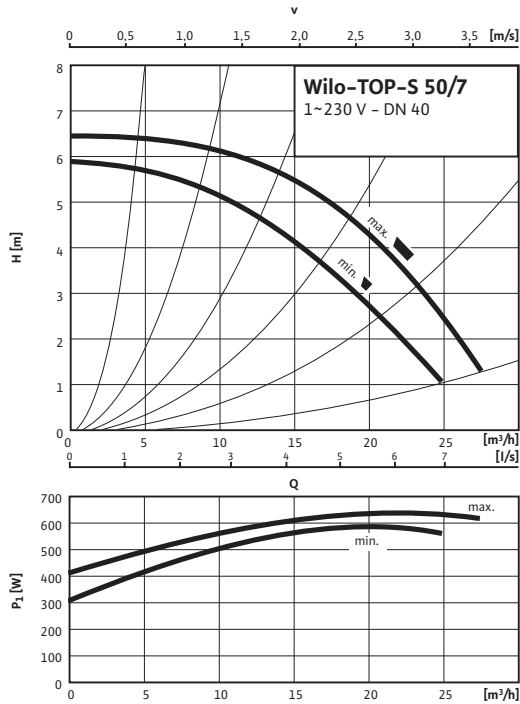

Three-phase current

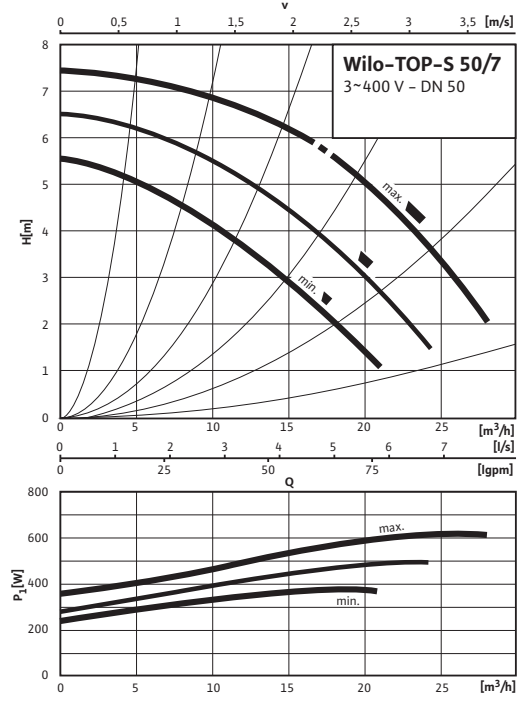

Wilo-TOP-S 50/10

Alternating current

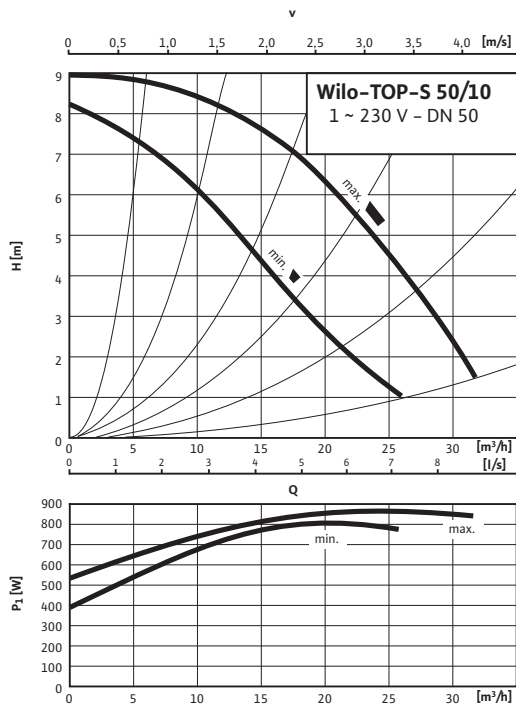

Three-phase current

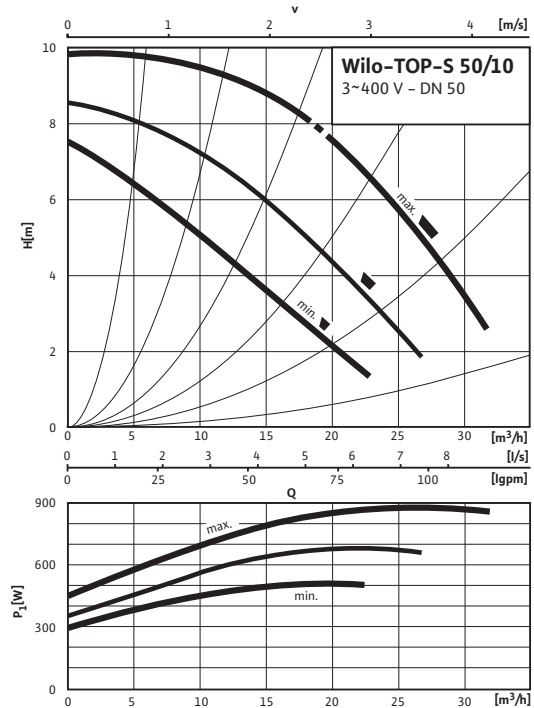

Pump curves Wilo-TOP-S

Wilo-TOP-S 50/15

Alternating current

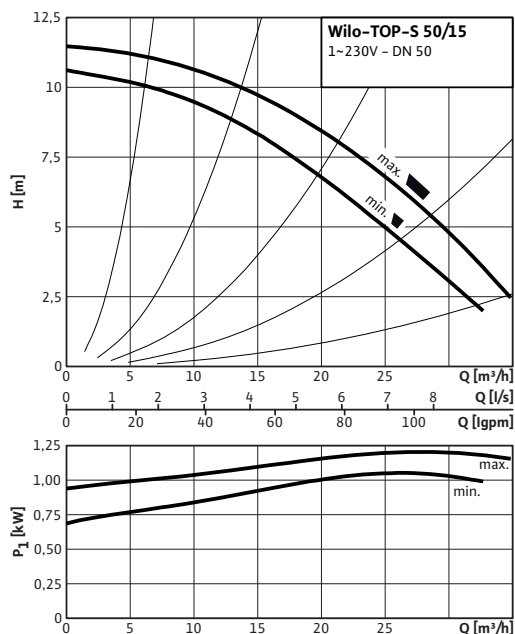

Three-phase current

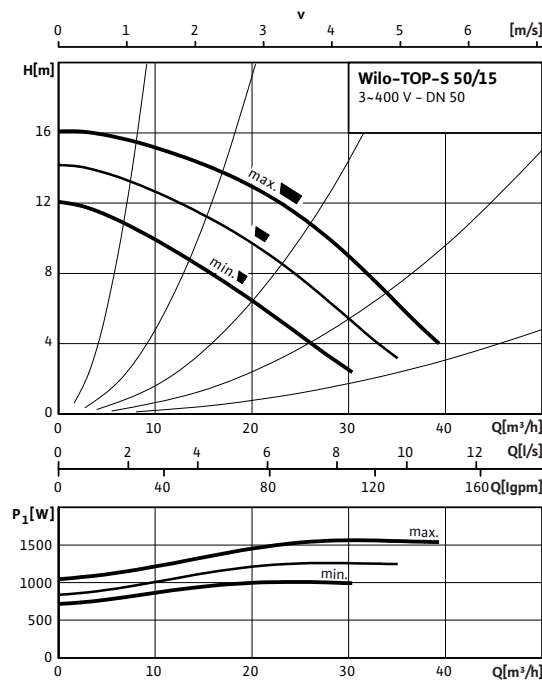

Wilo-TOP-S 65/7

Alternating current

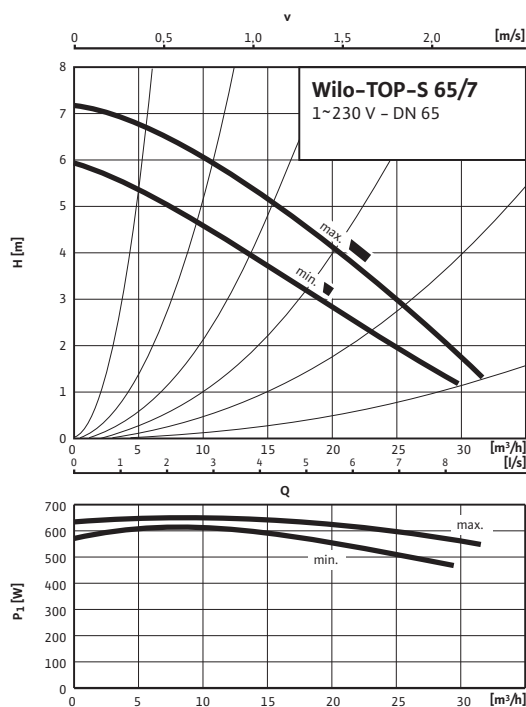

Three-phase current

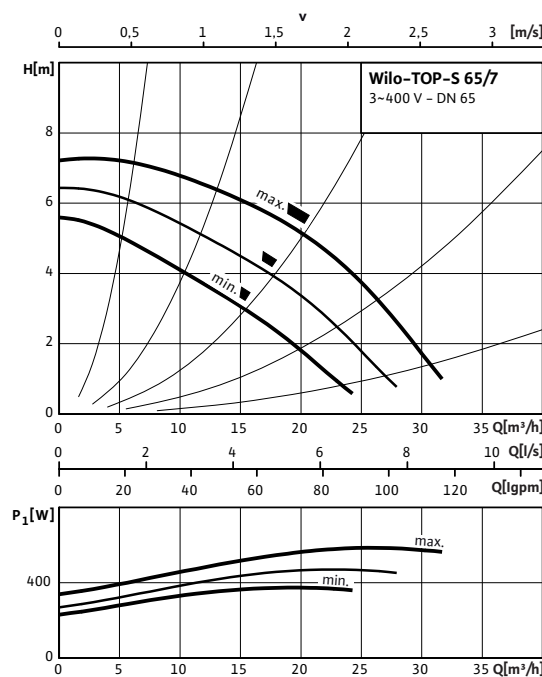

Heating, air-conditioning, cooling

Standard pumps (single pumps)

Pump curves Wilo-TOP-S

Wilo-TOP-S 65/10

Alternating current

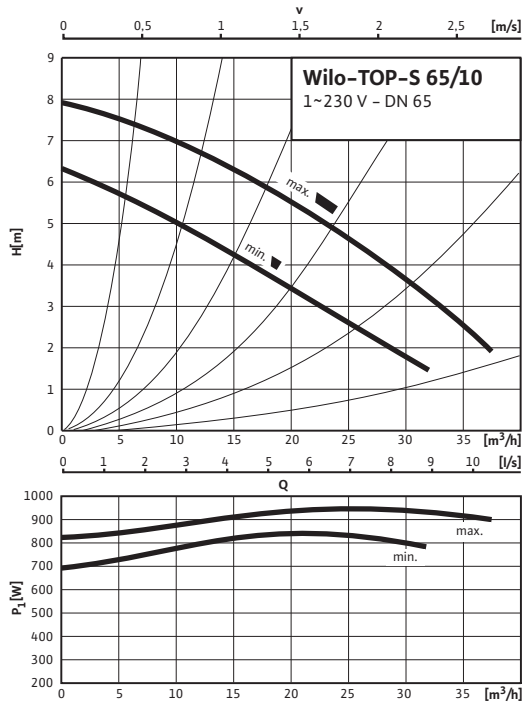

Three-phase current

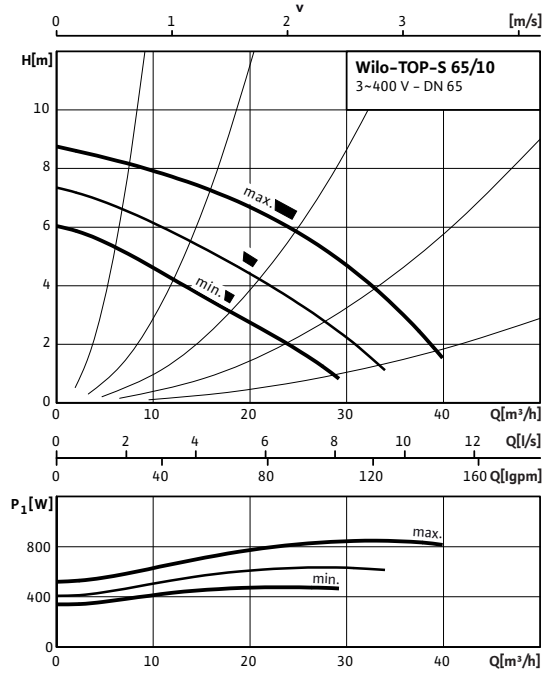

Wilo-TOP-S 65/13

Three-phase current

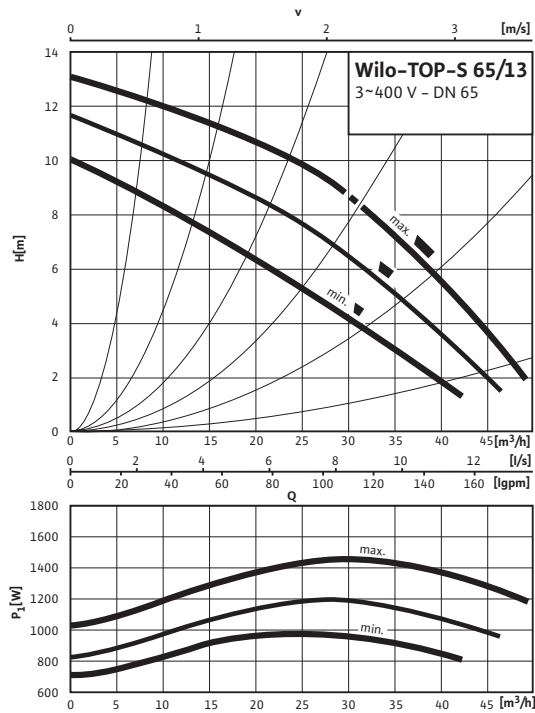

Three-phase current

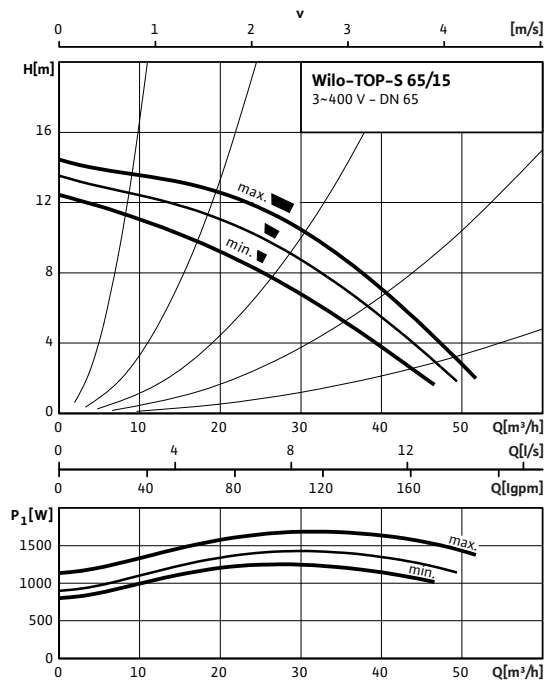

Pump curves Wilo-TOP-S

Wilo-TOP-S 80/7

Alternating current

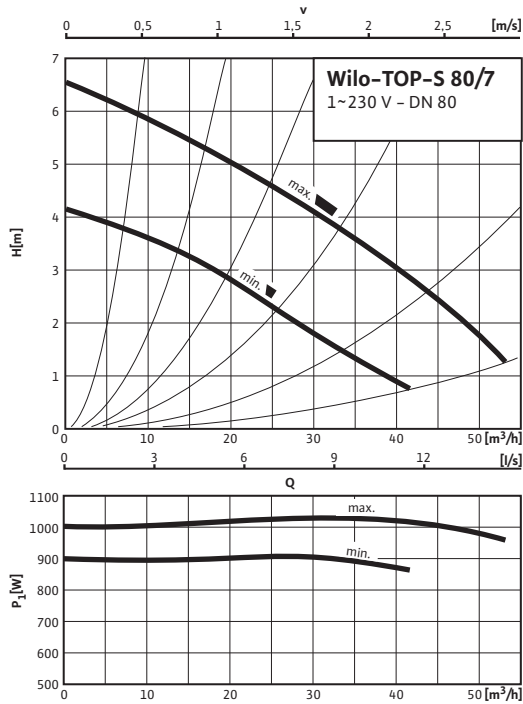

Three-phase current

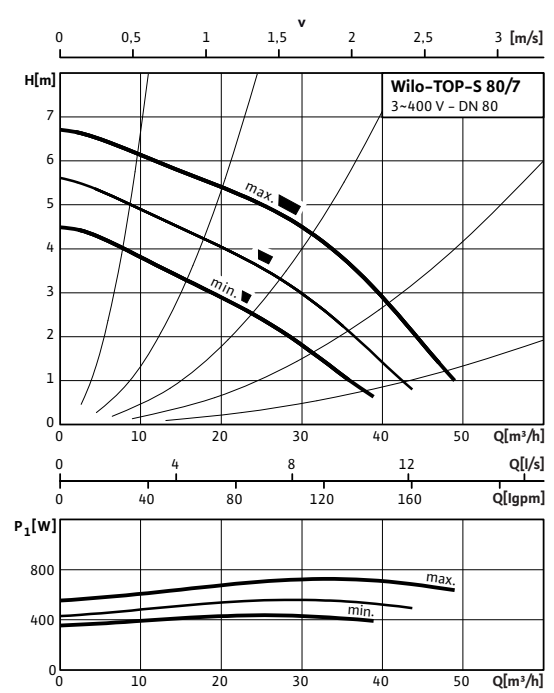

Wilo-TOP-S 80/10

Three-phase current

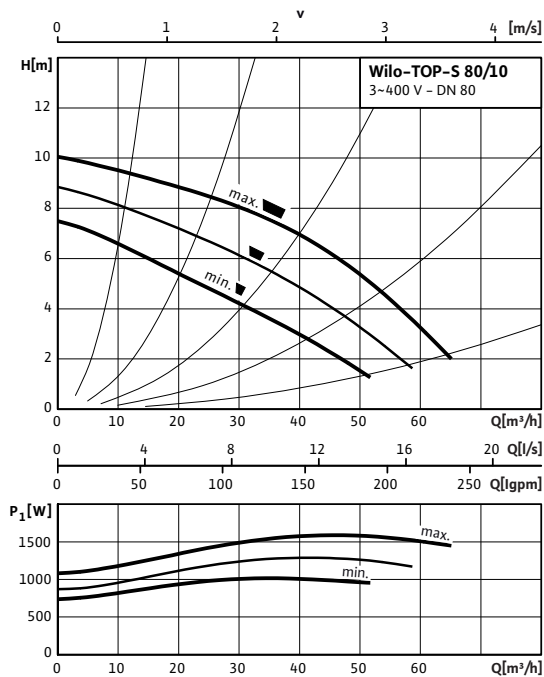

Three-phase current

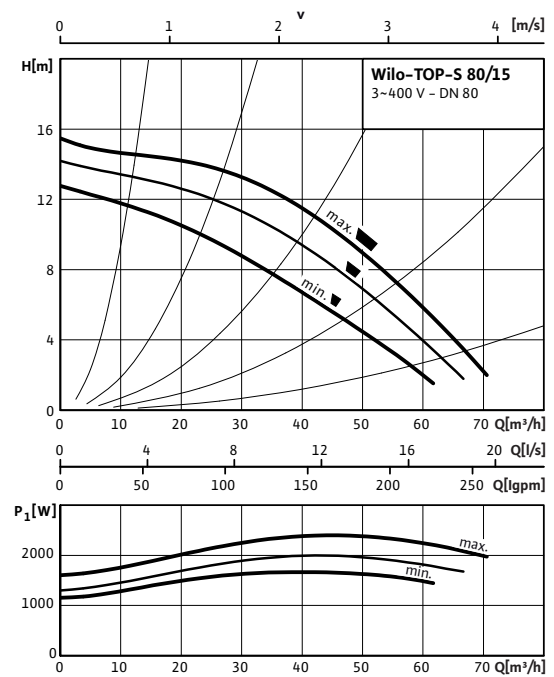

Heating, air-conditioning, cooling

Standard pumps (single pumps)

Pump curves Wilo-TOP-S

Wilo-TOP-S 80/20

Three-phase current

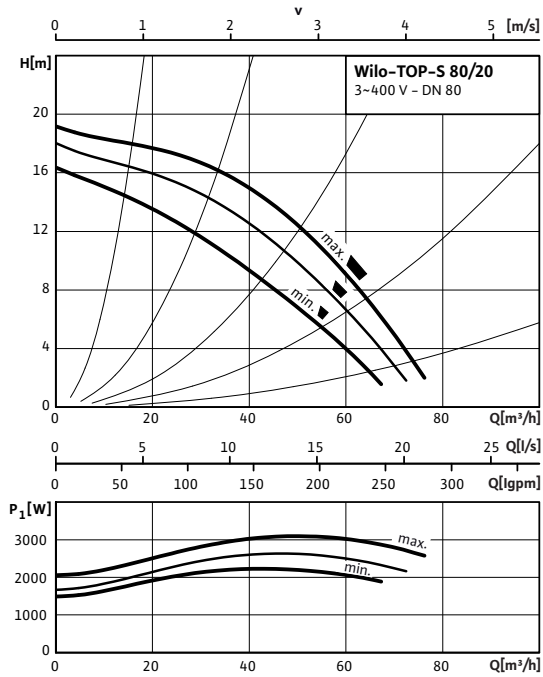

Wilo-TOP-S 100/10

Three-phase current

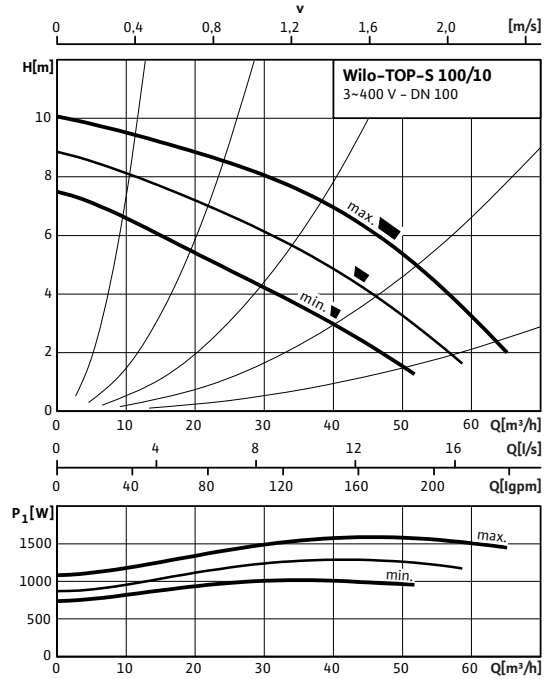

Terminal diagram, motor data Wilo-TOP-S

Terminal diagram A / motor protection A

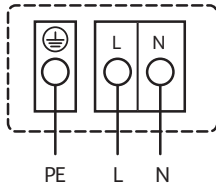

Mains connection 1~230 V, 50 Hz

Internal protection against unacceptably high winding temperatures
 Triggering: Internal interruption of motor voltage
 Reset: Automatic after motor has cooled down

Terminal diagram B / motor protection B

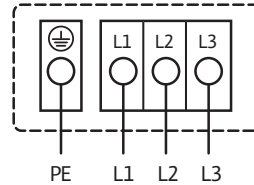

Mains connection 3~400 V, 50 Hz
 3~230 V, 50 Hz (with optional switching plug 3~230 V)
 internal protection against unacceptably high winding temperatures

Triggering: Internal interruption of a motor phase
 Reset: Disconnect mains voltage, allow motor to cool down,
 switch mains voltage back on again

Terminal diagram C / motor protection C

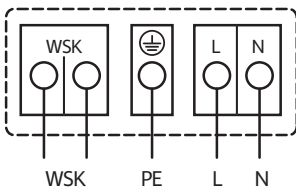

Mains connection 1~230 V, 50 Hz

WSK = thermal winding contact
 Full motor protection at all speed stages with optional tripping unit
 Wilo-SK 602/SK 622/Protect Module C or other switchgear/control devices
 with WSK connection option
 Triggering: External tripping at switchgear/control device
 Reset: Manual reset at switchgear/control device necessary

(Wiring diagram with SK 602/622, see "Service/Accessories")

Terminal diagram D / motor protection D

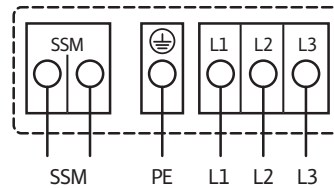

Mains connection 3~400 V, 50 Hz
 3~230 V, 50 Hz (with optional switching plug 3~230 V)
 Full motor protection with integrated trip electronics in terminal box for all
 speed stages
 Resolution: All-pole shutdown of motor by integrated
 trip electronics
 Reset: Manual reset at terminal box necessary

Load capacity of the potential-free NC contact according to VDI 3814 for the
 collective fault signal (SSM) 1 A, 250 V ~
 Function see "Wilo-Control pump management systems, Planning guide"

Terminal diagram F / motor protection F

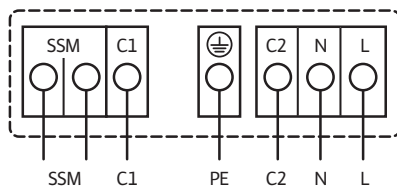

Mains connection 3~400 V, 50 Hz
 Full motor protection with integrated trip electronics in terminal box for all
 speed stages
 Resolution: All-pole shutdown of motor by integrated
 trip electronics
 Reset: Manual reset at terminal box necessary

Load capacity of the potential-free NC contact according to VDI 3814 for the
 collective fault signal (SSM) 1 A, 250 V ~
 Function see "Wilo-Control pump management systems, Planning guide"

Terminal diagram E / motor protection E

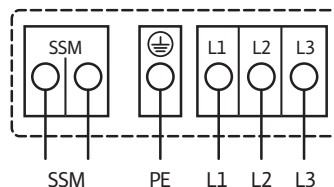

Mains connection 3~400 V, 50 Hz
 Full motor protection with integrated trip electronics in terminal box for all
 speed stages
 Resolution: All-pole shutdown of motor by integrated
 trip electronics
 Reset: Manual reset at terminal box necessary

Load capacity of the potential-free NC contact according to VDI 3814 for the
 collective fault signal (SSM) 1 A, 250 V ~
 Function see "Wilo-Control pump management systems, Planning guide"

Heating, air-conditioning, cooling

Standard pumps (single pumps)

Terminal diagram, motor data Wilo-TOP-S

| Motor data | | | | | | | | | | | |
|--------------------------|---------------------|--------------------------------|-------------------------------------|-------------------------------------|----------------------|----------------------|----------------------|-----------|------------------|---------------------------|----------------|
| Wilo-TOP-S ... | Nominal motor power | Speed | Power consumption 1~230 V | Power consumption 3~400 V | Current at 1~230V | Current at 3~400V | Current at 3~230V | Capacitor | Motor protection | Threaded cable connection | Wiring diagram |
| | P ₂ | n | P ₁ | | I | | | C | - | PG | - |
| | [W] | [rpm] | [W] | | [A] | | | [µF/VDB] | - | [PG] | - |
| 25/5 (1-phase-motor) | 50 | max. 2320 1640 min. 1200 | 100 - 140 75 - 110 55 - 75 | - | 0,65 0,55 0,35 | - | - | 3,7/400 | A | 1x13,5 | A |
| 25/5 (3-phase-motor) | 50 | max. 2650 2190 min. 1890 | - | 85 - 150 55 - 100 40 - 75 | - | 0,40 0,20 0,15 | 0,65 0,35 0,25 | - | B | 1x13,5 | B |
| 25/7 (1-phase-motor) | 90 | max. 2600 2300 min. 1800 | 140 - 195 110 - 175 85 - 120 | - | 0,95 0,87 0,62 | - | - | 5,0/400 | A | 1x13,5 | A |
| 25/7 (3-phase-motor) | 90 | max. 2600 2100 min. 1750 | - | 120 - 200 85 - 130 65 - 90 | - | 0,45 0,25 0,17 | 0,78 0,43 0,30 | - | B | 1x13,5 | B |
| 25/10 (1-phase-motor) | 180 | max. 2700 2550 min. 2400 | 225 - 390 190 - 385 165 - 335 | - | 1,9 1,87 1,72 | - | - | 8,0/400 | C | 2x13,5 | C |
| 25/10 (3-phase-motor) | 180 | max. 2650 2250 min. 1950 | - | 190 - 380 140 - 270 115 - 195 | - | 0,78 0,48 0,35 | 1,35 0,84 0,61 | - | D | 2x13,5 | D |
| 25/13 (1-phase-motor) | 100 | max. 2680 2380 min. 1800 | 183 - 260 150 - 200 112 - 130 | - | 1,24 0,96 0,65 | - | - | 6,0/400 | A | 1x13,5 | A |
| 25/13 (3-phase-motor) | 100 | max. 2680 2380 min. 1750 | - | 145 - 265 100 - 160 75 - 105 | - | 0,53 0,28 0,19 | 0,92 0,48 0,33 | - | B | 1x13,5 | B |
| 30/4 (1-phase-motor) | 70 | max. 2660 2340 min. 1710 | 145 - 180 95 - 150 70 - 110 | - | 0,85 0,75 0,55 | - | - | 5,0/400 | A | 1x13,5 | A |
| 30/4 (3-phase-motor) | 70 | max. 2610 2120 min. 1810 | - | 95 - 160 60 - 105 40 - 75 | - | 0,40 0,20 0,15 | 0,65 0,35 0,25 | - | B | 1x13,5 | B |
| 30/5 (1-phase-motor) | 50 | max. 2320 1640 min. 1200 | 110 - 140 75 - 110 55 - 75 | - | 0,65 0,55 0,35 | - | - | 3,7/400 | A | 1x13,5 | A |
| 30/5 (3-phase-motor) | 50 | max. 2650 2190 min. 1890 | - | 85 - 150 55 - 100 40 - 75 | - | 0,40 0,20 0,15 | 0,65 0,35 0,25 | - | B | 1x13,5 | B |
| 30/7 (1-phase-motor) | 90 | max. 2600 2300 min. 1800 | 140 - 195 110 - 175 85 - 120 | - | 0,95 0,87 0,62 | - | - | 5,0/400 | A | 1x13,5 | A |
| 30/7 (3-phase-motor) | 90 | max. 2600 2100 min. 1750 | - | 120 - 200 85 - 130 65 - 90 | - | 0,45 0,25 0,17 | 0,78 0,43 0,30 | - | B | 1x13,5 | B |

Terminal diagram, motor data Wilo-TOP-S

| Motor data | | | | | | | | | | | |
|-----------------------|---------------------|--------------------------------|-------------------------------------|-------------------------------------|----------------------|----------------------|----------------------|--------------|------------------|---------------------------|----------------|
| Wilo-TOP-S ... | Nominal motor power | Speed | Power consumption 1~230 V | Power consumption 3~400 V | Current at 1~230V | Current at 3~400V | Current at 3~230V | Capacitor | Motor protection | Threaded cable connection | Wiring diagram |
| | P ₂ | n | P ₁ | | I | | | C | – | PG | – |
| | [W] | [rpm] | [W] | | [A] | | | [µF/VDB] | – | [PG] | – |
| 30/10 (1-phase-motor) | 180 | max. 2700 2550 min. 2400 | 225 - 390 190 - 385 165 - 335 | – | 1,9 1,87 1,72 | – | – | 8,0/400 | C | 2x13,5 | C |
| 30/10 (3-phase-motor) | 180 | max. 2650 2250 min. 1950 | – | 190 - 380 140 - 270 115 - 195 | – | 0,78 0,48 0,35 | 1,35 0,84 0,61 | – | D | 2x13,5 | D |
| 40/4 (1-phase-motor) | 90 | max. 2500 2100 min. 1600 | 155 - 195 130 - 175 100 - 120 | – | 0,95 0,87 0,62 | – | – | 5,0/400 | A | 1x13,5 | A |
| 40/4 (3-phase-motor) | 90 | max. 2550 2050 min. 1700 | – | 145 - 195 100 - 130 70 - 90 | – | 0,45 0,25 0,17 | 0,78 0,43 0,30 | – | B | 1x13,5 | B |
| 40/7 (1-phase-motor) | 180 | max. 2650 2450 min. 2200 | 250 - 390 220 - 380 200 - 330 | – | 1,93 1,88 1,7 | – | – | 8,0/400 | C | 2x13,5 | C |
| 40/7 (3-phase-motor) | 180 | max. 2600 2100 min. 1800 | – | 220 - 370 165 - 260 130 - 185 | – | 0,76 0,47 0,33 | 1,31 0,81 0,57 | – | D | 2x13,5 | D |
| 40/10 (1-phase-motor) | 350 | max. 2800 min. 2600 | 430 - 680 310 - 610 | – | 3,47 3,18 | – | – | 16,0/ 400 | F | 2x13,5 | F |
| 40/10 (3-phase-motor) | 350 | max. 2800 2500 min. 2200 | – | 300 - 585 230 - 465 200 - 365 | – | 1,17 0,82 0,65 | 2,02 1,43 1,12 | – | D | 2x13,5 | D |
| 40/15 (1-phase-motor) | 570 | max. 2800 min. 2500 | 615 - 945 415 - 800 | – | 4,57 4,2 | – | – | 25,0/ 400 | F | 2x13,5 | F |
| 40/15 (3-phase-motor) | 570 | max. 2800 2500 min. 2150 | – | 500 - 905 375 - 720 325 - 585 | – | 1,84 1,30 1,05 | 3,19 2,25 1,82 | – | D | 2x13,5 | D |
| 50/4 (1-phase-motor) | 180 | max. 2650 2450 min. 1950 | 280 - 330 255 - 320 235 - 290 | – | 1,62 1,61 1,51 | – | – | 8,0/400 | C | 2x13,5 | C |
| 50/4 (3-phase-motor) | 180 | max. 2600 2100 min. 1700 | – | 245 - 330 190 - 240 145 - 180 | – | 0,71 0,44 0,32 | 1,23 0,76 0,56 | – | D | 2x13,5 | D |
| 50/7 (1-phase-motor) | 350 | max. 2800 min. 2600 | 460 - 690 360 - 630 | – | 3,49 3,35 | – | – | 16,0/ 400 | F | 2x13,5 | F |
| 50/7 (3-phase-motor) | 350 | max. 2800 2450 min. 2150 | – | 360 - 610 285 - 470 245 - 375 | – | 1,19 0,83 0,66 | 2,06 1,43 1,14 | – | D | 2x13,5 | D |
| 50/10 (1-phase-motor) | 450 | max. 2800 min. 2450 | 515 - 820 360 - 730 | – | 3,94 3,72 | – | – | 25,0/ 400 | F | 2x13,5 | F |
| 50/10 (3-phase-motor) | 450 | max. 2700 2300 min. 2000 | – | 450 - 880 330 - 680 280 - 500 | – | 1,73 1,20 0,89 | 3,00 2,09 1,54 | – | D | 2x13,5 | D |

Heating, air-conditioning, cooling

Standard pumps (single pumps)

Terminal diagram, motor data Wilo-TOP-S

| Motor data | | | | | | | | | | | |
|---------------------------|---------------------|--------------------------------|---------------------------|---|-------------------|----------------------|----------------------|--------------|------------------|---------------------------|----------------|
| Wilo-TOP-S ... | Nominal motor power | Speed | Power consumption 1~230 V | Power consumption 3~400 V | Current at 1~230V | Current at 3~400V | Current at 3~230V | Capacitor | Motor protection | Threaded cable connection | Wiring diagram |
| | P ₂ | n | P ₁ | | I | | | C | – | PG | – |
| | [W] | [rpm] | [W] | | [A] | | | [µF/VDB] | – | [PG] | – |
| 50/15 (3-phase-motor) | 1100 | max. 2800 2500 min. 2200 | – | 1060 - 1570 830 - 1260 720 - 1005 | – | 3,13 2,25 1,81 | 5,43 3,90 3,14 | – | D | 2x13,5 | D |
| 65/7 (1-phase-motor) | 350 | max. 2800 min. 2550 | 460 - 690 350 - 630 | – | 3,49 3,35 | – | – | 16.0/ 400 | F | 2x13,5 | F |
| 65/7 (3-phase-motor) | 350 | max. 2800 2450 min. 2150 | – | 340 - 590 270 - 470 235 - 375 | – | 1,16 0,82 0,66 | 2,01 1,42 1,14 | – | D | 2x13,5 | D |
| 65/10 (1-phase-motor) | 450 | max. 2800 min. 2450 | 580 - 790 440 - 690 | – | 3,78 3,51 | – | – | 25.0/ 400 | F | 2x13,5 | F |
| 65/10 (3-phase-motor) | 450 | max. 2650 2250 min. 1950 | – | 525 - 845 410 - 630 340 - 470 | – | 1,67 1,10 0,83 | 2,89 1,91 1,44 | – | D | 2x13,5 | D |
| 65/13 (3-phase-motor) | 1100 | max. 2800 2550 min. 2250 | – | 1000 - 1450 810 - 1180 700 - 960 | – | 2,93 2,10 1,74 | 5,07 3,64 3,00 | – | D | 2x13,5 | D |
| 65/15 (3-phase-motor) | 1300 | max. 2850 2700 min. 2500 | – | 1140 - 1685 910 - 1425 810 - 1240 | – | 3,41 2,52 2,18 | 5,91 4,36 3,78 | – | D | 2x13,5 | D |
| 80/7 (1-phase-motor) | 450 | max. 2800 min. 2350 | 640 - 800 505 - 700 | – | 3,85 3,59 | – | – | 25.0/ 400 | F | 2x13,5 | F |
| 80/7 (3-phase-motor) | 450 | max. 2700 2400 min. 2100 | – | 560 - 730 430 - 560 350 - 440 | – | 1,53 1,00 0,79 | 2,65 1,74 1,36 | – | D | 2x13,5 | D |
| 80/10 (3-phase-motor) | 1100 | max. 2800 2500 min. 2150 | – | 1100 - 1590 880 - 1290 745 - 1015 | – | 3,13 2,29 1,84 | 5,43 3,96 3,19 | – | D | 2x13,5 | D |
| 80/15 (3-phase-motor) | 1800 | max. 2900 2700 min. 2450 | – | 1600 - 2400 1300 - 2000 1160 - 1680 | – | 4,85 3,63 3,25 | – | – | E | 2x13,5 | E |
| 80/20 (3-phase-motor) | 2200 | max. 2900 2750 min. 2500 | – | 2050 - 3120 1670 - 2650 1480 - 2270 | – | 6,10 4,80 4,35 | – | – | E | 2x13,5 | E |
| 100/10 (3-phase-motor) | 1100 | max. 2800 2500 min. 2150 | – | 1100 - 1590 880 - 1290 745 - 1015 | – | 3,13 2,29 1,84 | 5,43 3,96 3,19 | – | D | 2x13,5 | D |

Observe name plate data!

Current I: Motor protection switch onsite setting

Note:

Mains connection 3~230 V with optional switching plug (accessory)

Dimensions, weights Wilo-TOP-S

Dimension drawing A

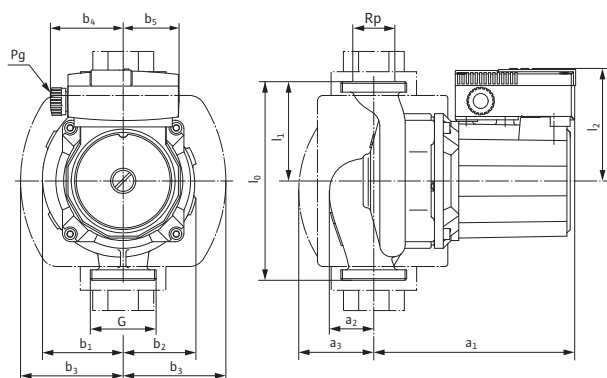

Permitted installation positions, see Planning guide

Dimension drawing B

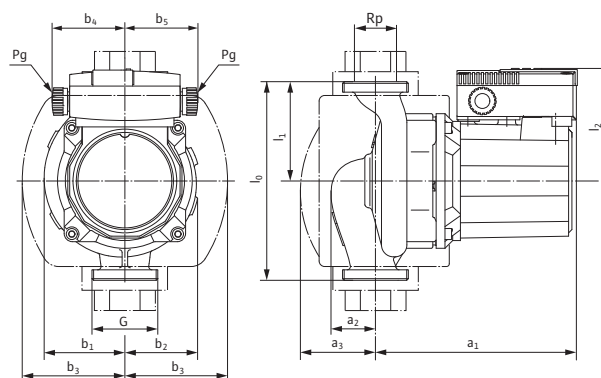

Permitted installation positions, see Planning guide

Dimension drawing C

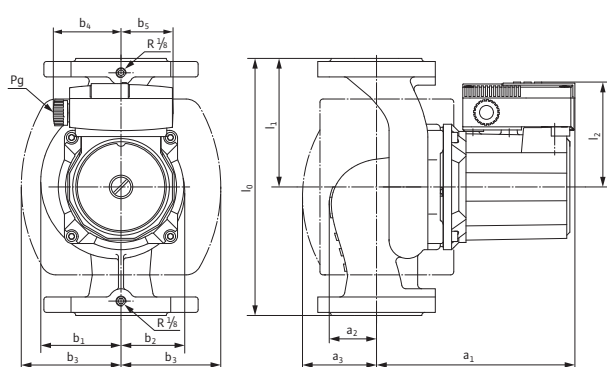

Permitted installation positions, see Planning guide

Dimension drawing D

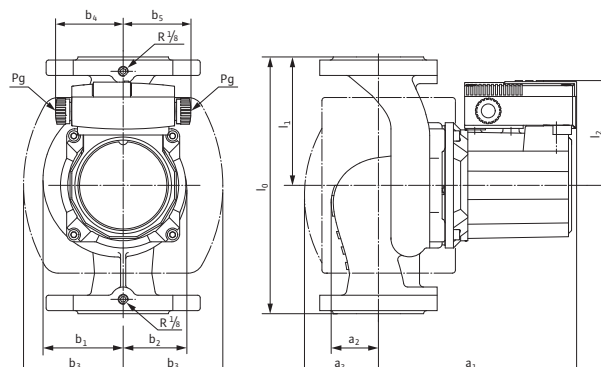

Permitted installation positions, see Planning guide

Dimension drawing E

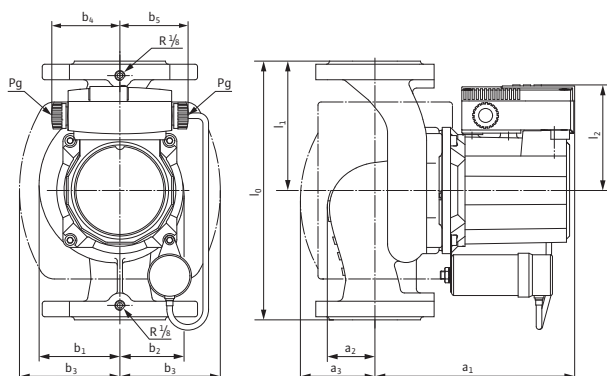

Permitted installation positions, see Planning guide

Heating, air-conditioning, cooling

Standard pumps (single pumps)

Dimensions, weights Wilo-TOP-S

Dimension drawing Flange F

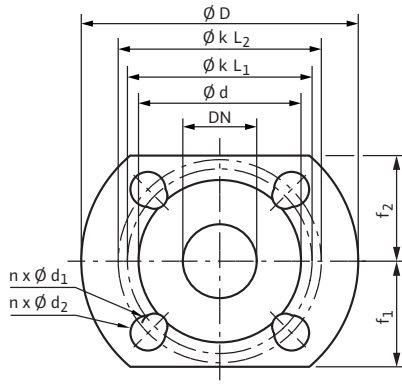

Dimension drawing Flange G

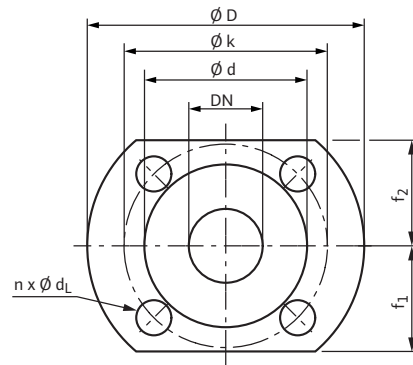

Dimensions, weights

| Wilo-TOP-S ... | Rated pressure | Pipe connection | Nominal flange diameter | Thread | Dimensions | | | | | | | | | Weight approx. | Dimension drawing | |
|----------------|----------------|-----------------|-------------------------|--------|----------------|----------------|----------------|----------------|----------------|----------------|----------------|----------------|----------------|----------------|-------------------|---|
| | PN | Rp | DN | G | l ₀ | l ₂ | a ₁ | a ₂ | b ₁ | b ₂ | b ₃ | b ₄ | b ₅ | M | | – |
| | [bar] | – | | | [mm] | | | | | | | | | [kg] | | – |
| 25/5 | 10 | 1 | – | 1½ | 180 | 92 | 150 | 40 | 50 | 52 | 88 | 60 | 44 | 5.0 | A | |
| 25/7 | 10 | 1 | – | 1½ | 180 | 92 | 165 | 34 | 66 | 56 | 80 | 60 | 44 | 5.0 | A | |
| 25/10 | 10 | 1 | – | 1½ | 180 | 102 | 172 | 45 | 69 | 68 | 92 | 66 | 66 | 6.3 | B | |
| 25/13 | 10 | 1 | – | 1½ | 180 | 92 | 156 | 30 | 68 | 64 | 89 | 60 | 44 | 5.2 | A | |
| 30/4 | 10 | 1¼ | – | 2 | 180 | 92 | 156 | 50 | 53 | 65 | 88 | 60 | 44 | 5.0 | A | |
| 30/5 | 10 | 1¼ | – | 2 | 180 | 92 | 150 | 40 | 50 | 52 | 88 | 60 | 44 | 5.0 | A | |
| 30/7 | 10 | 1¼ | – | 2 | 180 | 92 | 172 | 34 | 66 | 57 | 88 | 60 | 44 | 5.0 | A | |
| 30/10 | 10 | 1¼ | – | 2 | 180 | 102 | 172 | 45 | 69 | 69 | 92 | 66 | 66 | 6.3 | B | |
| 40/4 | 6/10 | – | 40 | – | 220 | 90 | 178 | 54 | 84 | 60 | 102 | 53 | 44 | 9.5 | C | |
| 40/7 | 6/10 | – | 40 | – | 250 | 102 | 193 | 46 | 78 | 68 | 102 | 66 | 66 | 11.0 | D | |
| 40/10 | 6/10 | – | 40 | – | 250 | 109 | 216 | 59 | 90 | 80 | 117 | 66 | 66 | 14.7 | D | |
| 40/15 | 6/10 | – | 40 | – | 250 | 119 | 258 | 55 | 99 | 86 | 137 | 66 | 66 | 20.8 | D | |
| 50/4 | 6/10 | – | 50 | – | 240 | 102 | 200 | 53 | 94 | 68 | 117 | 66 | 66 | 13.1 | D | |
| 50/7 | 6/10 | – | 50 | – | 280 | 109 | 224 | 65 | 91 | 77 | 125 | 66 | 66 | 16.6 | D | |
| 50/10 | 6/10 | – | 50 | – | 280 | 109 | 222 | 71 | 101 | 87 | 125 | 66 | 66 | 17.8 | D | |
| 50/15 | 6/10 | – | 50 | – | 340 | 119 | 242 | 81 | 105 | 90 | 139 | 66 | 66 | 24.9 | D | |
| 65/7 | 6/10 | – | 65 | – | 280 | 109 | 226 | 67 | 95 | 79 | 125 | 66 | 66 | 18.5 | D | |
| 65/10 | 6/10 | – | 65 | – | 340 | 109 | 241 | 67 | 110 | 89 | 132 | 66 | 66 | 21.0 | D | |
| 65/13 | 6/10 | – | 65 | – | 340 | 119 | 254 | 81 | 118 | 98 | 142 | 66 | 66 | 27.2 | D | |
| 65/15 | 6/10 | – | 65 | – | 340 | 119 | 254 | 81 | 118 | 98 | 142 | 66 | 66 | 30.4 | D | |
| 80/7 | 6 | – | 80 | – | 360 | 109 | 227 | 80 | 116 | 89 | 140 | 66 | 66 | 23.4 | E | |
| 80/7 | 10 | – | 80 | – | 360 | 109 | 227 | 80 | 116 | 89 | 140 | 66 | 66 | 23.2 | D | |
| 80/10 | 6 | – | 80 | – | 360 | 119 | 256 | 95 | 135 | 107 | 162 | 66 | 66 | 30.1 | D | |
| 80/10 | 10 | – | 80 | – | 360 | 119 | 256 | 95 | 135 | 107 | 162 | 66 | 66 | 30.1 | D | |
| 80/15 | 6 | – | 80 | – | 360 | 143 | 316 | 89 | 129 | 108 | 152 | 66 | 66 | 42.1 | D | |
| 80/15 | 10 | – | 80 | – | 360 | 143 | 316 | 89 | 129 | 108 | 152 | 66 | 66 | 42.1 | D | |