

# MULTI-SPEED COMMERCIAL HEATING CIRCULATORS



**GRUNDFOS<sup>®</sup>**



# FOR TODAY'S LOW ENERGY HEATING

- GLANDLESS HEATING CIRCULATORS FOR PIPELINE MOUNTING
- VARIABLE DUTY
- FLOWS UP TO 30 LITRES/SEC PRESSURES UP TO 105 kN/m<sup>2</sup>
- FOR MAXIMUM SYSTEM PRESSURE OF 6 BARS\*
- WATER TEMPERATURES UP TO 120°C
- PUMP HOUSING FLANGED TO BS4504: 1969 TABLE 6/11
- SCREWED BOSS COUNTER FLANGES, BOLTS AND GASKETS INCLUDED
- NINE SINGLE AND TWIN HEAD MODELS FOR 3 PHASE OPERATION
- SIX SINGLE AND TWIN HEAD MODELS FOR SINGLE PHASE OPERATION
- FLAP VALVE FITTED AS STANDARD ON ALL TWIN HEAD MODELS

\*EXCEPT UPS 40 MODELS WITH 2" BSP FLANGES, WHICH ARE 4 BAR ONLY.



**THREE SPEED MOTOR  
FOR FLEXIBILITY AND  
ENERGY SAVING**

# SYSTEMS — IT MUST BE GRUNDFOS

## Better System Control:

Grundfos Multi-Speed has been developed for today's heating industry, which demands energy saving, combined with variable flow rates, to meet the requirements of flexible modern low energy systems.

Multi-Speed flow control combinations are:

*Manual*, selecting ideal flow rates by simply interchanging plugs on the pump terminal casing, to meet system requirements.

*Automatic programming*, to meet both higher daytime heating demands, and set-back for reduced night-time duty.

## Saves Energy:

Grundfos motor development now offers tomorrow's concept today, with energy conserving pump motors. The Multi-Speed motor ensures that no energy is dissipated unnecessarily throughout its variable range of duties. For example, model UPS 80-120 requires 2200 watts input at normal speed (3), only 1700 watts at speed 2, and just 490 watts at the lowest speed setting (1).

A reduction in power consumption of over 70%! Grundfos Multi-Speed saves power.

Three pump speeds that can be controlled manually or programmed. Variable duty for flexibility and economy.

Flooded rotor can construction means no leaking shaft seals.

Die-cast aluminium alloy motor housing for better heat dissipation, cooler running and reduced weight.

Stainless steel rotor can, rotor cladding and impeller for resistance to corrosion and silky-smooth operation.

Multi-Speed is quiet running and is maintenance-free, having water lubricated bearings.

Suction and discharge ports are tapped for addition of pressure switches or gauges.

Every pump is tested for smooth, quiet operation under simulated working conditions at 90°C, and is guaranteed for 12 months.

## TWIN HEAD MODELS FOR DUTY/ STANDBY OR HIGHER PERFORMANCE



## STAINLESS STEEL AND CERAMICS FOR VITAL PUMP COMPONENTS

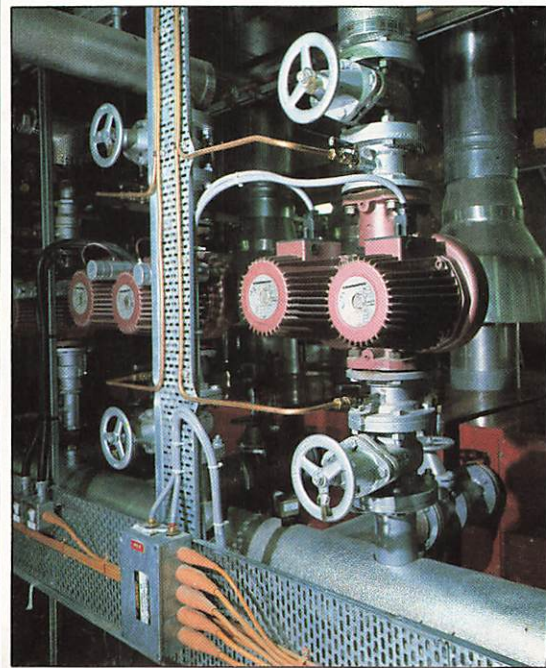

# PERFORMANCE RANGE - SINGLE HEAD MODELS

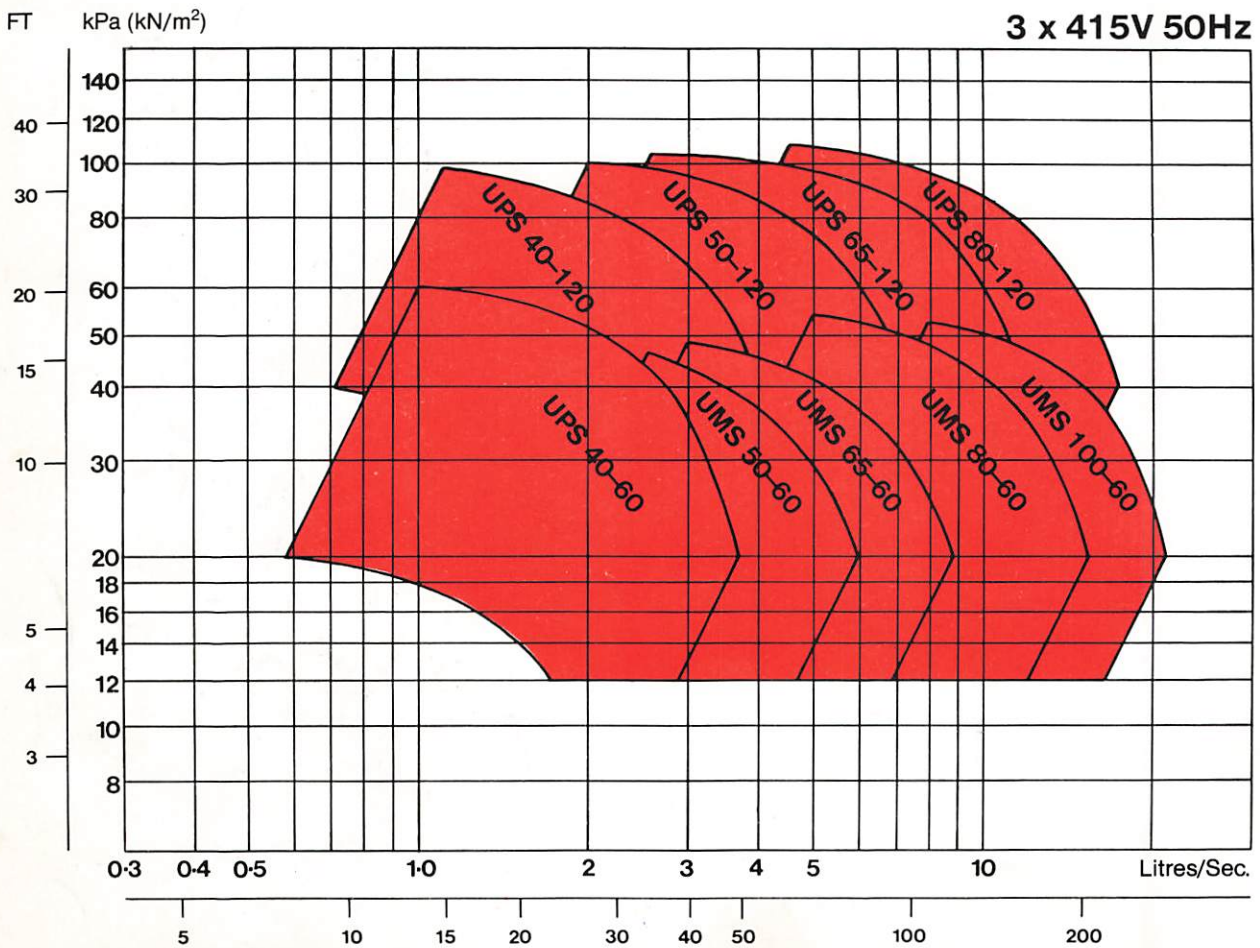
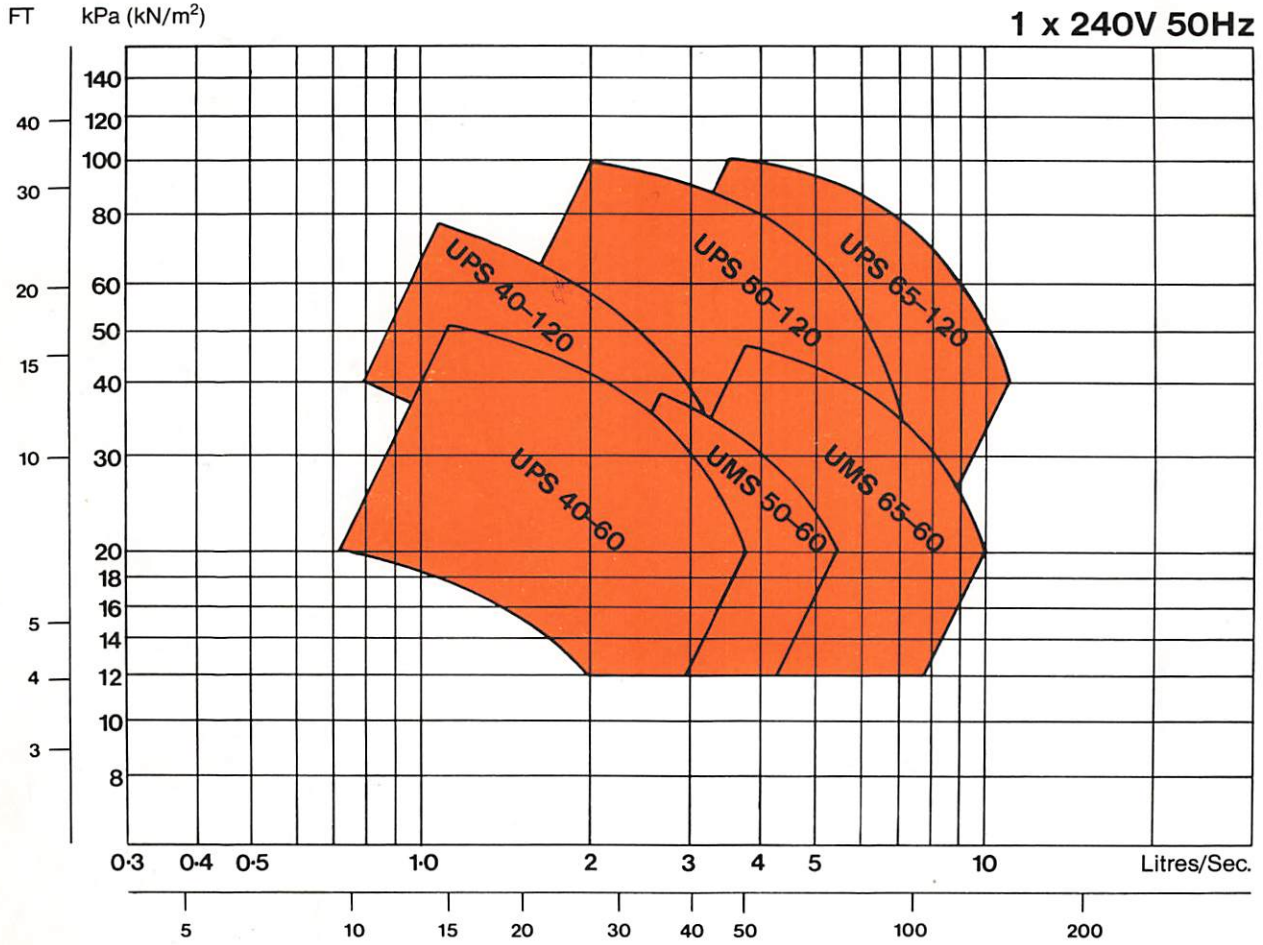

# PERFORMANCE RANGE - TWIN HEAD MODELS (ONE HEAD OPERATING)

FT kPa (kN/m<sup>2</sup>)

1 x 240V 50Hz

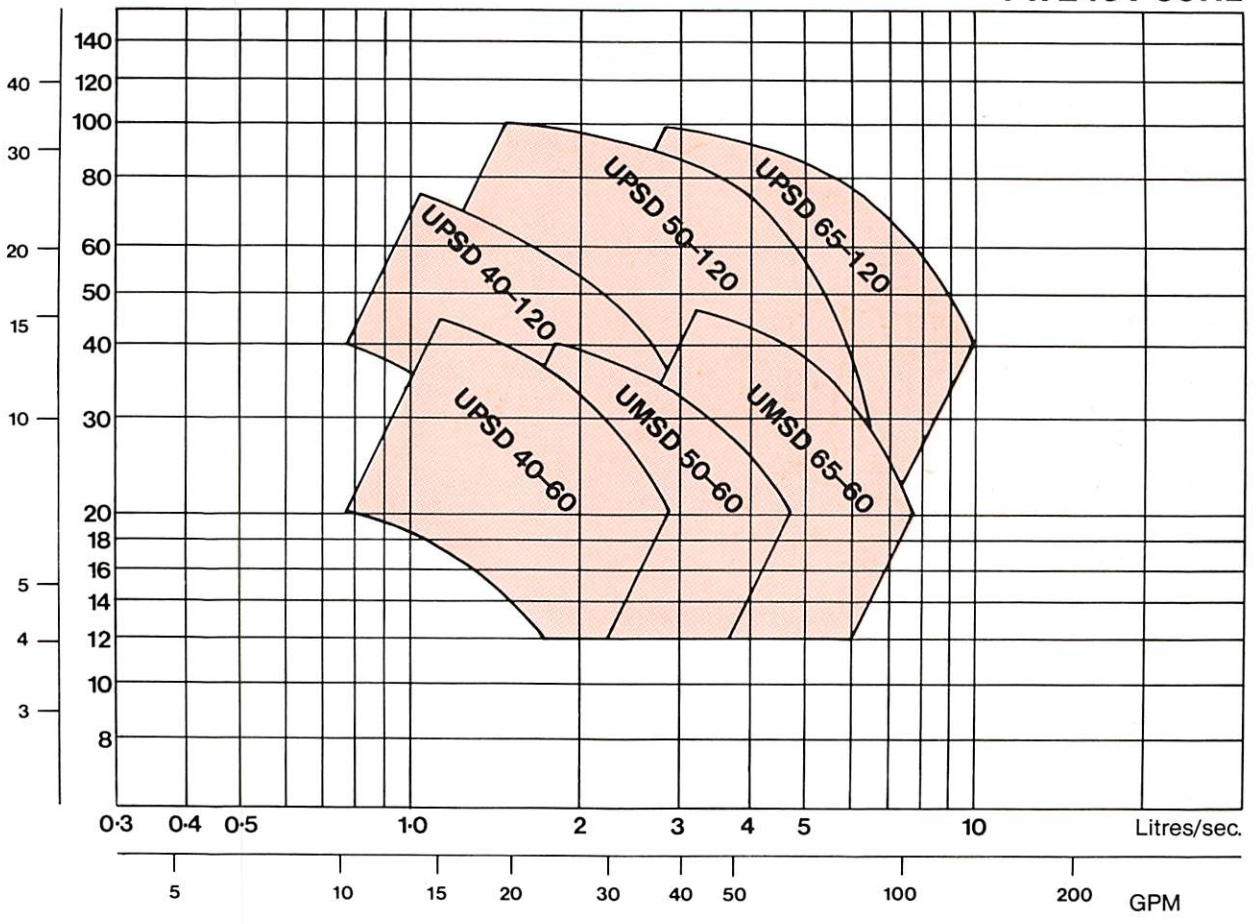

FT kPa (kN/m<sup>2</sup>)

3 x 415V 50Hz

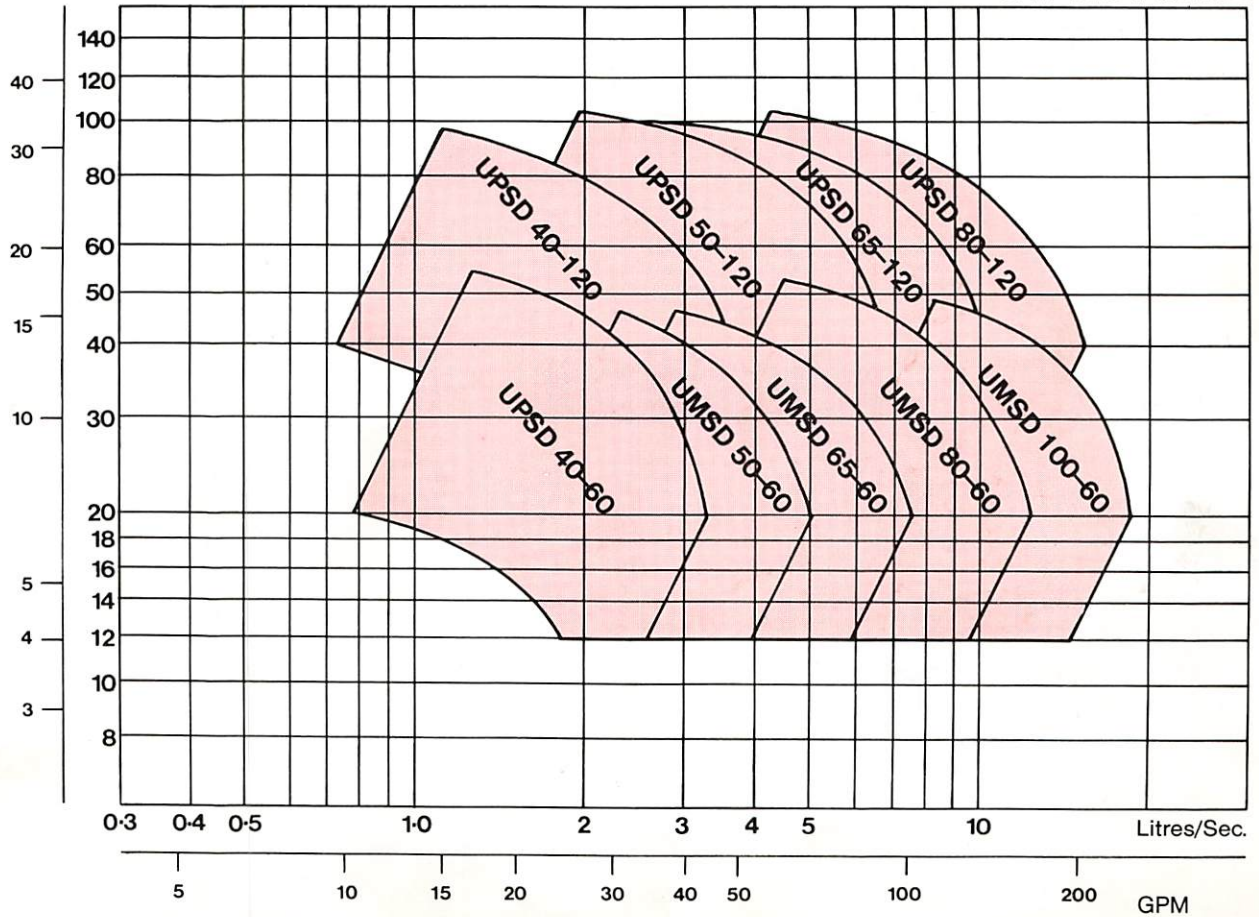

# SINGLE HEAD MODELS 1 x 240V 50Hz



## ELECTRICAL DATA

SPEED	R.P.M.	INPUT POWER WATTS	FULL LOAD CURRENT AMPS 1 x 240V	CAPACITOR RATING
③	2350	300	1.42	6 $\mu$ f
②	2000	280	1.34	6 $\mu$ f
①	1600	215	1.03	6 $\mu$ f

Maximum permissible power consumption:  
All motors are suitable for the values shown plus 10 per cent overload.

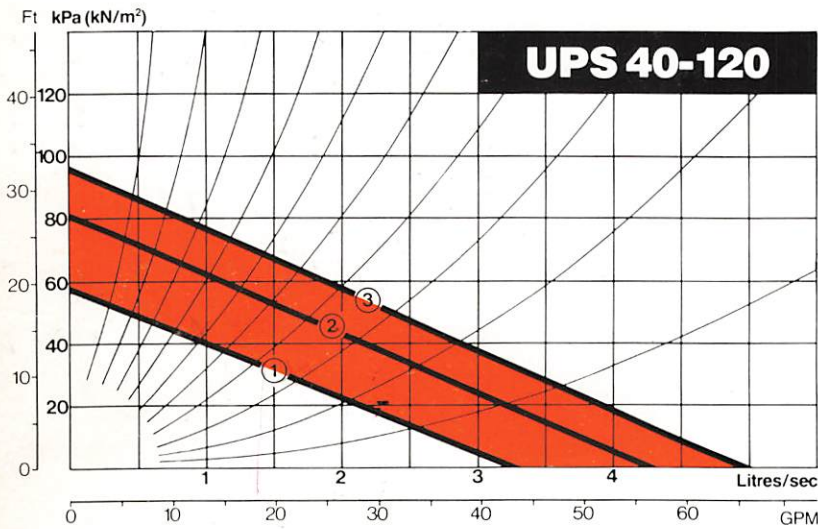

## ELECTRICAL DATA

SPEED	R.P.M.	INPUT POWER WATTS	FULL LOAD CURRENT AMPS 1 x 240V	CAPACITOR RATING
③	2350	435	1.92	12 $\mu$ f
②	2100	390	1.81	12 $\mu$ f
①	1700	305	1.45	12 $\mu$ f

Maximum permissible power consumption:  
All motors are suitable for the values shown plus 10 per cent overload.

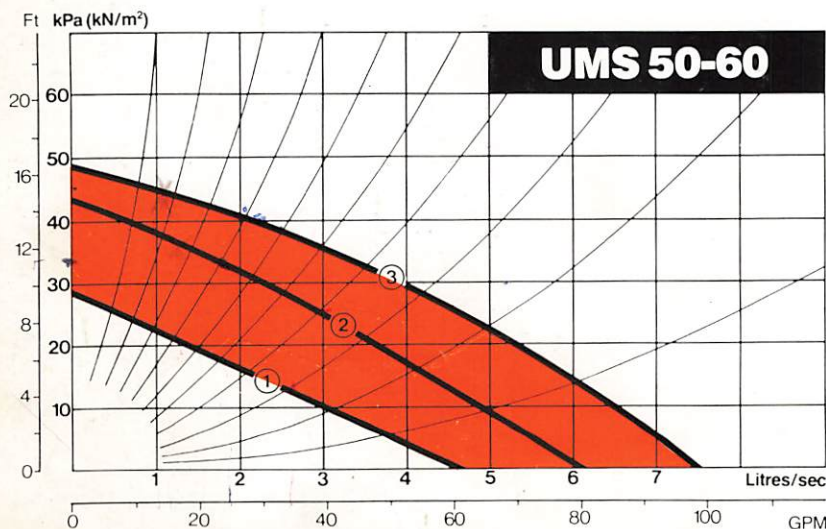

## ELECTRICAL DATA

SPEED	R.P.M.	INPUT POWER WATTS	FULL LOAD CURRENT AMPS 1 x 240V	CAPACITOR RATING
③	1200	440	1.85	12 $\mu$ f
②	1050	375	1.75	12 $\mu$ f
①	800	260	1.25	12 $\mu$ f

Maximum permissible power consumption:  
All motors are suitable for the values shown plus 10 per cent overload.

# TWIN HEAD MODELS 1 x 240V 50Hz

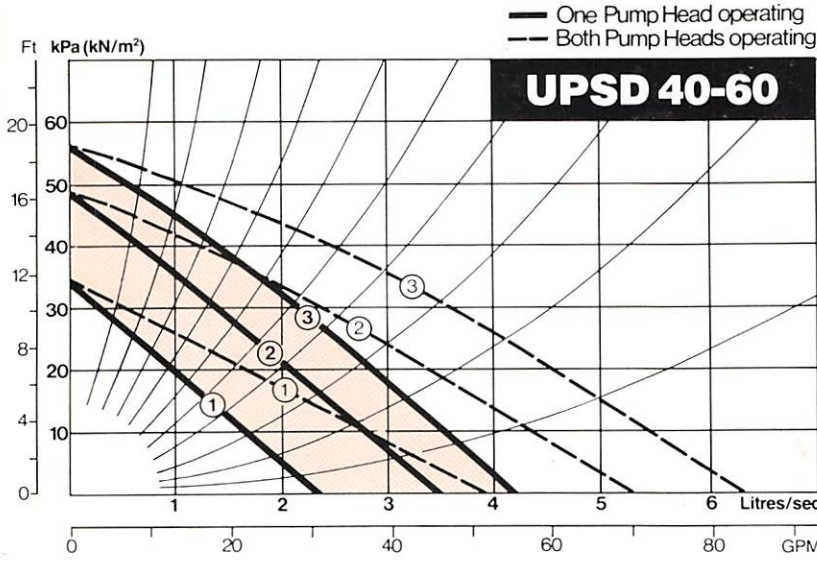

## ELECTRICAL DATA FOR ONE HEAD IN OPERATION

SPEED	R.P.M.	INPUT POWER WATTS	FULL LOAD CURRENT AMPS 1 x 240V	CAPACITOR RATING
③	2350	300	1.42	6µf
②	2000	280	1.34	6µf
①	1600	215	1.03	6µf

## ELECTRICAL DATA FOR EACH HEAD WHEN BOTH ARE OPERATING IN PARALLEL

SPEED	R.P.M.	INPUT POWER WATTS	FULL LOAD CURRENT AMPS 1 x 240V	CAPACITOR RATING
③	2350	290	1.33	2 x 6µf
②	2000	270	1.29	2 x 6µf
①	1600	205	1.01	2 x 6µf

Maximum permissible power consumption:  
All motors are suitable for the values shown plus 10 per cent overload.

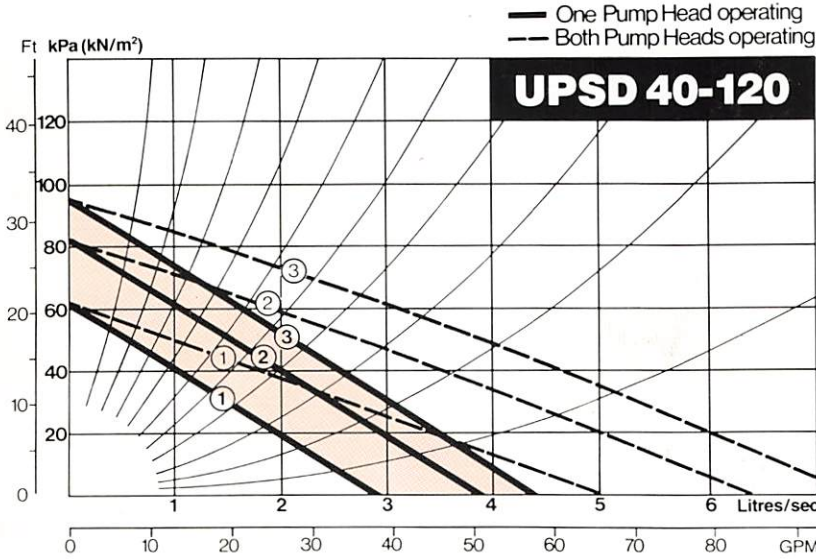

## ELECTRICAL DATA FOR ONE HEAD IN OPERATION

SPEED	R.P.M.	INPUT POWER WATTS	FULL LOAD CURRENT AMPS 1 x 240V	CAPACITOR RATING
③	2350	435	1.92	12µf
②	2100	390	1.81	12µf
①	1700	305	1.45	12µf

## ELECTRICAL DATA FOR EACH HEAD WHEN BOTH ARE OPERATING IN PARALLEL

SPEED	R.P.M.	INPUT POWER WATTS	FULL LOAD CURRENT AMPS 1 x 240V	CAPACITOR RATING
③	2350	435	1.91	2 x 12µf
②	2100	390	1.80	2 x 12µf
①	1700	305	1.44	2 x 12µf

Maximum permissible power consumption:  
All motors are suitable for the values shown plus 10 per cent overload.

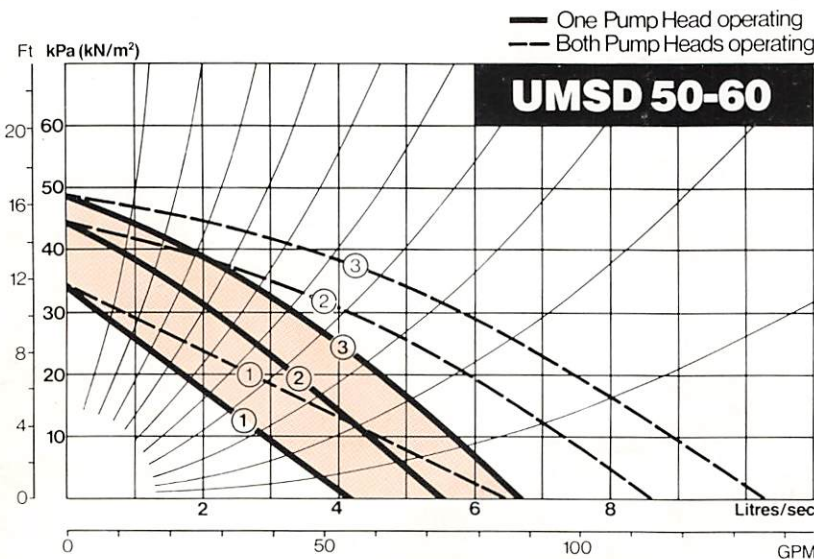

## ELECTRICAL DATA FOR ONE HEAD IN OPERATION

SPEED	R.P.M.	INPUT POWER WATTS	FULL LOAD CURRENT AMPS 1 x 240V	CAPACITOR RATING
③	1200	440	1.85	12µf
②	1050	375	1.75	12µf
①	800	260	1.25	12µf

## ELECTRICAL DATA FOR EACH HEAD WHEN BOTH ARE OPERATING IN PARALLEL

SPEED	R.P.M.	INPUT POWER WATTS	FULL LOAD CURRENT AMPS 1 x 240V	CAPACITOR RATING
③	1200	415	1.78	2 x 12µf
②	1050	355	1.63	2 x 12µf
①	800	255	1.20	2 x 12µf

Maximum permissible power consumption:  
All motors are suitable for the values shown plus 10 per cent overload.

# SINGLE HEAD MODELS 1 x 240V 50Hz

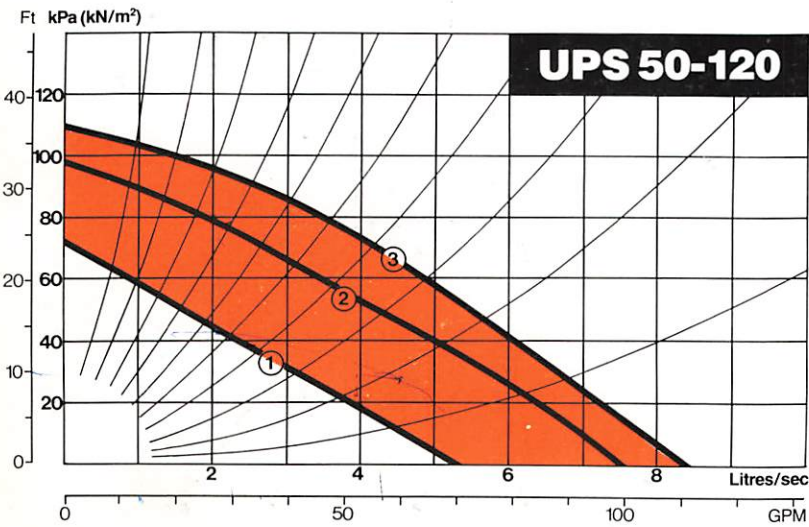

## ELECTRICAL DATA

SPEED	R.P.M.	INPUT POWER WATTS	FULL LOAD CURRENT AMPS 1 x 240V	CAPACITOR RATING
3	2525	840	3.71	16µf
2	2245	830	3.83	16µf
1	1655	675	3.22	16µf

Maximum permissible power consumption:  
All motors are suitable for the values shown plus 10 per cent overload.

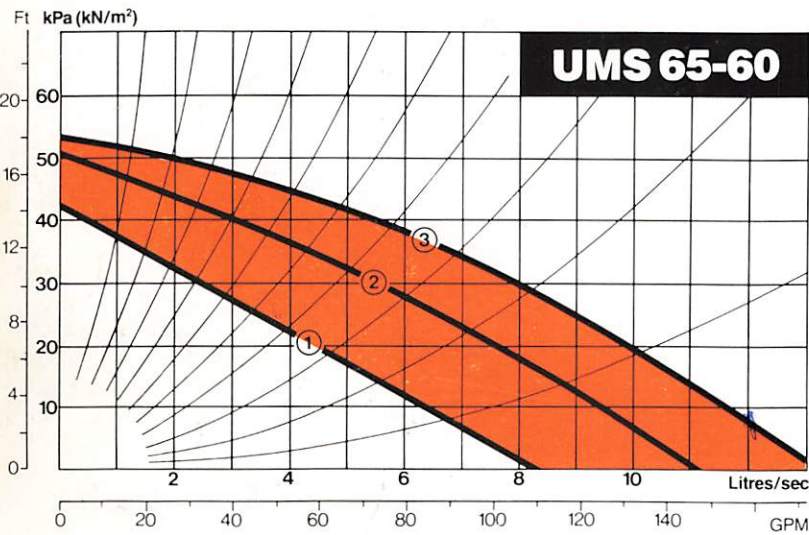

## ELECTRICAL DATA

SPEED	R.P.M.	INPUT POWER WATTS	FULL LOAD CURRENT AMPS 1 x 240V	CAPACITOR RATING
3	1300	800	3.35	25µf
2	1150	670	2.95	25µf
1	1000	475	2.25	25µf

Maximum permissible power consumption:  
All motors are suitable for the values shown plus 10 per cent overload.

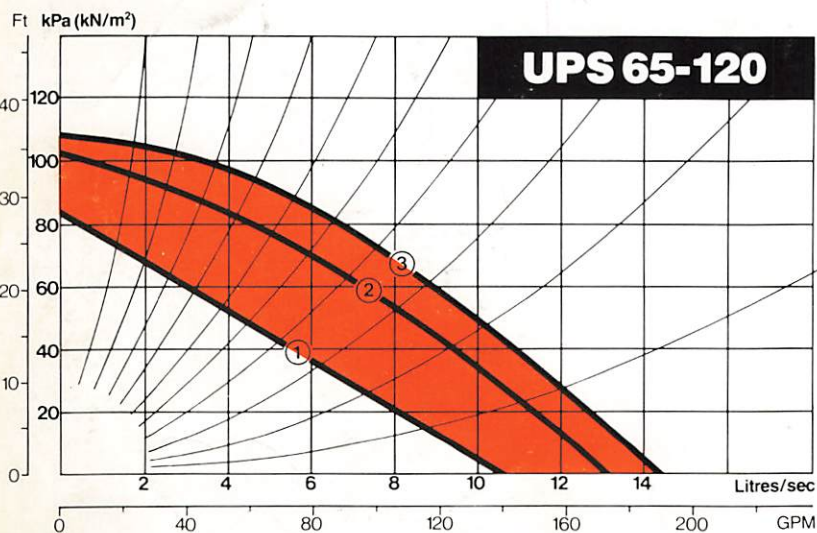

## ELECTRICAL DATA

SPEED	R.P.M.	INPUT POWER WATTS	FULL LOAD CURRENT AMPS 1 x 240V	CAPACITOR RATING
3	2700	1455	6.10	30µf
2	2500	1360	5.95	30µf
1	2150	1150	5.10	30µf

Maximum permissible power consumption:  
All motors are suitable for the values shown plus 10 per cent overload.

# TWIN HEAD MODELS 1 x 240V 50Hz

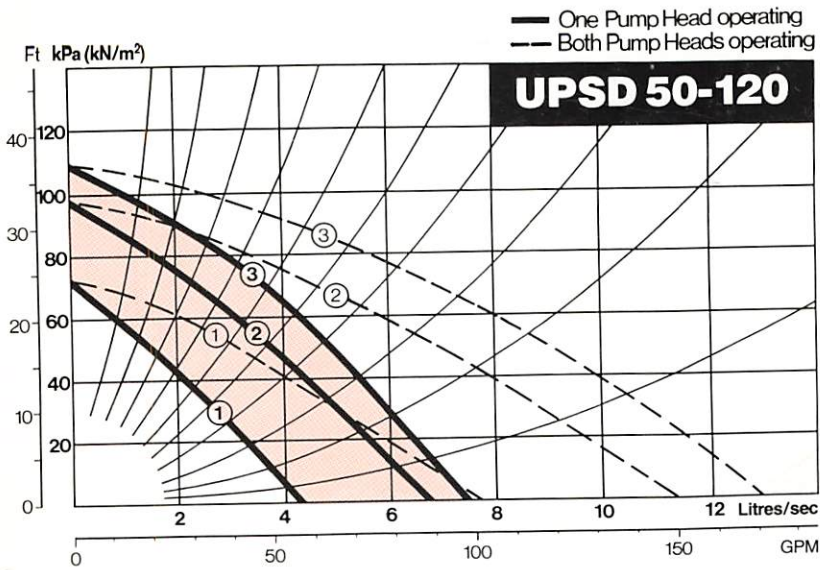

## ELECTRICAL DATA FOR ONE HEAD IN OPERATION

SPEED	R.P.M.	INPUT POWER WATTS	FULL LOAD CURRENT AMPS 1 x 240V	CAPACITANCE
③	2525	840	3.71	1
②	2245	830	3.83	1
①	1655	675	3.22	

## ELECTRICAL DATA FOR EACH HEAD WHEN BOTH ARE OPERATING IN PARALLEL

SPEED	R.P.M.	INPUT POWER WATTS	FULL LOAD CURRENT AMPS 1 x 240V	CAPACITANCE
③	2525	840	3.71	2 x
②	2245	830	3.83	2 x
①	1655	675	3.22	2 x

Maximum permissible power consumption:  
All motors are suitable for the values shown plus 10 per cent overload.

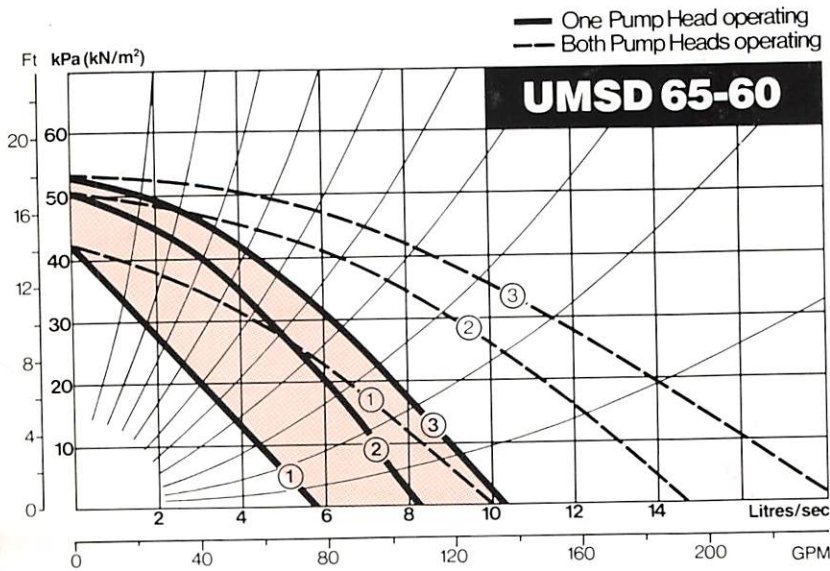

## ELECTRICAL DATA FOR ONE HEAD IN OPERATION

SPEED	R.P.M.	INPUT POWER WATTS	FULL LOAD CURRENT AMPS 1 x 240V	CAPACITANCE
③	1300	800	3.35	
②	1150	670	2.95	
①	1000	475	2.25	

## ELECTRICAL DATA FOR EACH HEAD WHEN BOTH ARE OPERATING IN PARALLEL

SPEED	R.P.M.	INPUT POWER WATTS	FULL LOAD CURRENT AMPS 1 x 240V	CAPACITANCE
③	1300	725	3.00	2
②	1150	565	2.58	2
①	1000	415	1.95	2

Maximum permissible power consumption:  
All motors are suitable for the values shown plus 10 per cent overload.

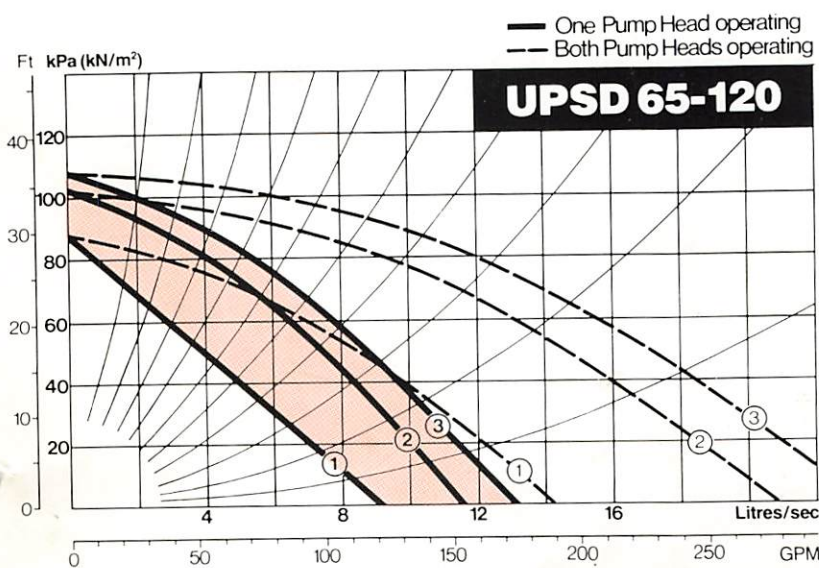

## ELECTRICAL DATA FOR ONE HEAD IN OPERATION

SPEED	R.P.M.	INPUT POWER WATTS	FULL LOAD CURRENT AMPS 1 x 240V	CAPACITANCE
③	2700	1455	6.10	
②	2500	1360	5.95	
①	2150	1150	5.10	

## ELECTRICAL DATA FOR EACH HEAD WHEN BOTH ARE OPERATING IN PARALLEL

SPEED	R.P.M.	INPUT POWER WATTS	FULL LOAD CURRENT AMPS 1 x 240V	CAPACITANCE
③	2700	1430	5.90	
②	2500	1325	5.70	
①	2150	1125	4.95	

Maximum permissible power consumption:  
All motors are suitable for the values shown plus 10 per cent overload.

# SINGLE HEAD MODELS 3 x 415V 50Hz

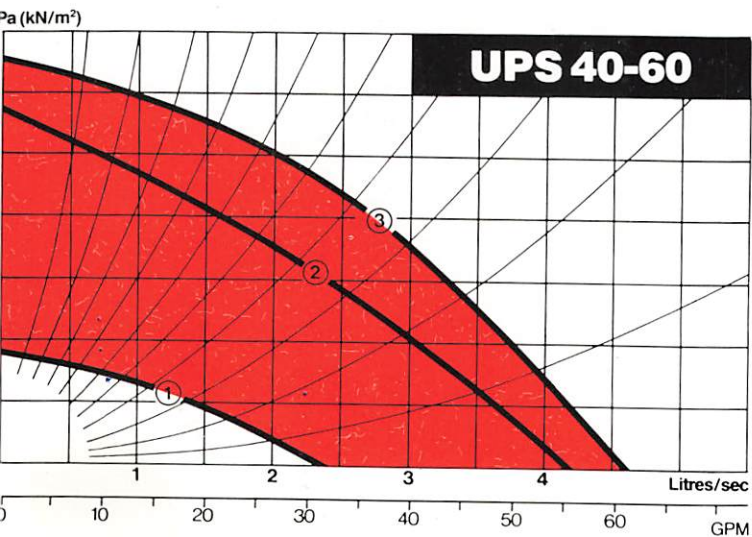

## ELECTRICAL DATA

SPEED	R.P.M.	INPUT POWER WATTS	FULL LOAD CURRENT AMPS 3 x 415V
③	2820	345	0.73
②	2450	240	0.41
①	1450	180	0.50

Maximum permissible power consumption:  
All motors are suitable for the values shown plus 10 per cent overload.

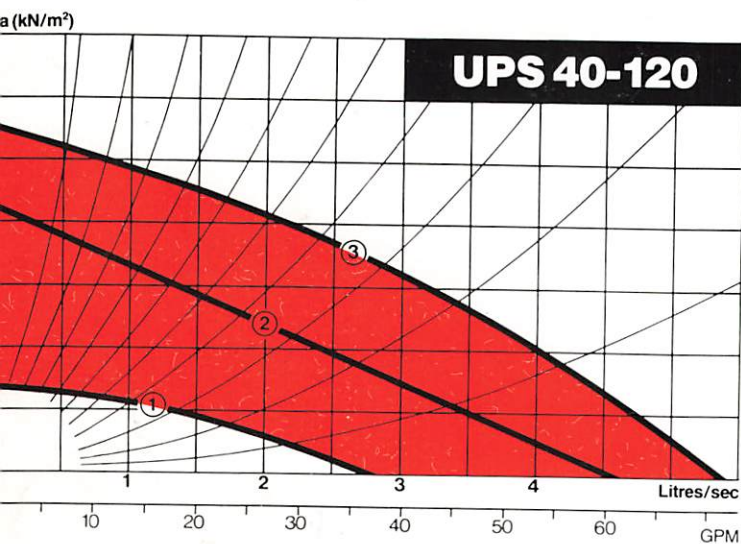

## ELECTRICAL DATA

SPEED	R.P.M.	INPUT POWER WATTS	FULL LOAD CURRENT AMPS 3 x 415V
③	2750	600	1.15
②	2200	415	0.64
①	1450	230	0.69

Maximum permissible power consumption:  
All motors are suitable for the values shown plus 10 per cent overload.

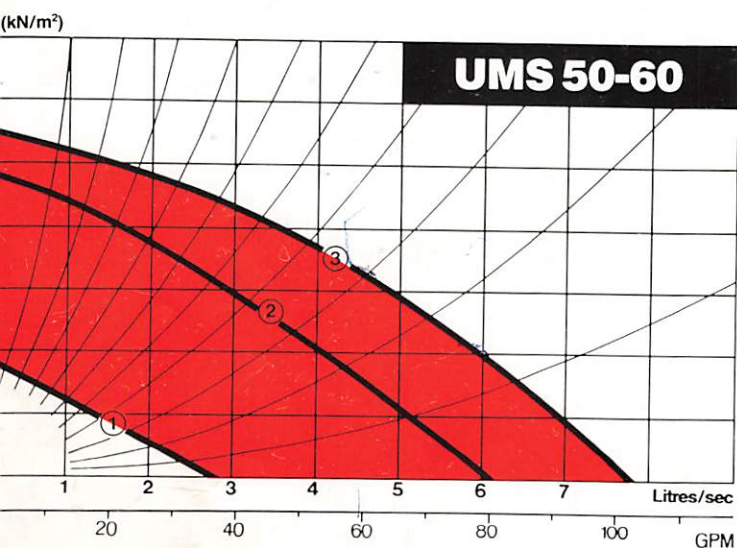

## ELECTRICAL DATA

SPEED	R.P.M.	INPUT POWER WATTS	FULL LOAD CURRENT AMPS 3 x 415V
③	1380	450	1.00
②	1180	310	0.55
①	650	115	0.23

Maximum permissible power consumption:  
All motors are suitable for the values shown plus 10 per cent overload.

# TWIN HEAD MODELS 3 x 415V 50Hz

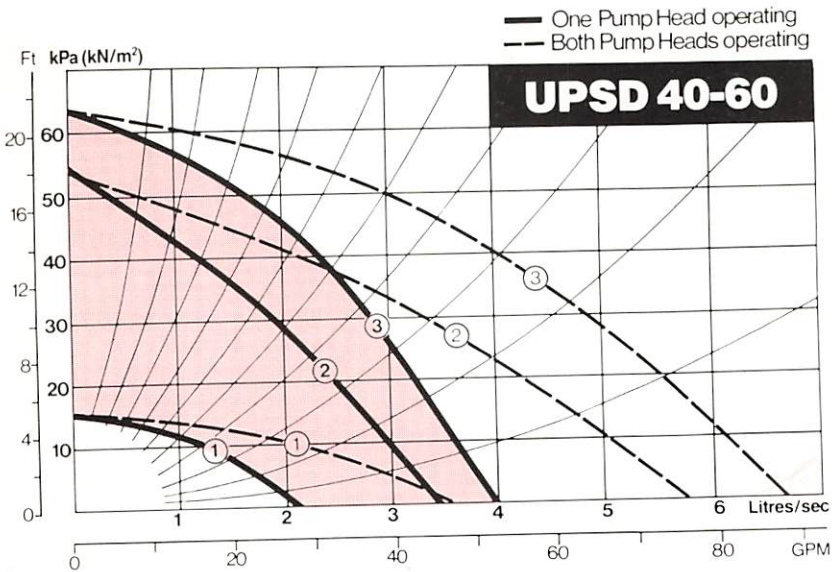

## ELECTRICAL DATA FOR ONE HEAD IN OPERATION

SPEED	R.P.M.	INPUT POWER WATTS	FULL LOAD CURRENT AMPS 3 x 415V
③	2820	345	0.73
②	2450	240	0.41
①	1450	180	0.50

## ELECTRICAL DATA FOR EACH HEAD WHEN BOTH ARE OPERATING IN PARALLEL

SPEED	R.P.M.	INPUT POWER WATTS	FULL LOAD CURRENT AMPS 3 x 415V
③	2820	320	0.71
②	2450	230	0.38
①	1450	165	0.49

Maximum permissible power consumption:  
All motors are suitable for the values shown plus 10 per cent overload.

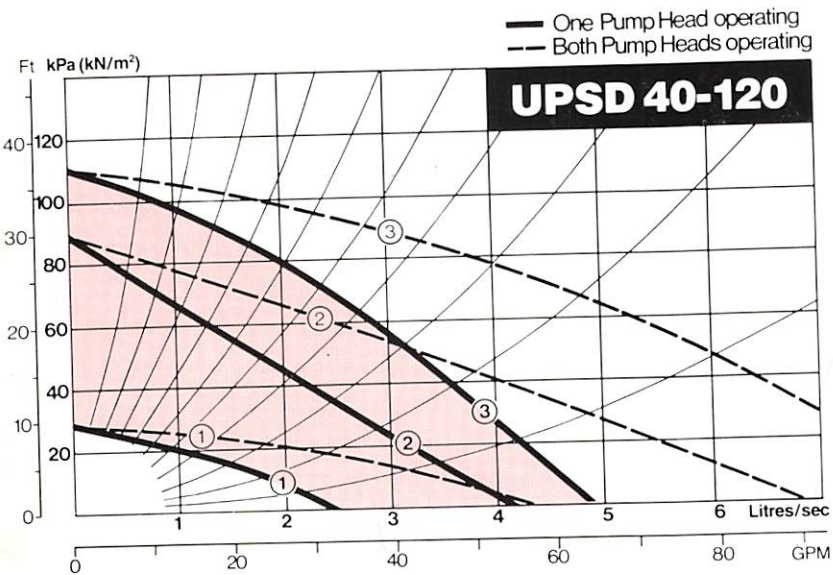

## ELECTRICAL DATA FOR ONE HEAD IN OPERATION

SPEED	R.P.M.	INPUT POWER WATTS	FULL LOAD CURRENT AMPS 3 x 415V
③	2750	600	1.15
②	2200	415	0.64
①	1450	230	0.69

## ELECTRICAL DATA FOR EACH HEAD WHEN BOTH ARE OPERATING IN PARALLEL

SPEED	R.P.M.	INPUT POWER WATTS	FULL LOAD CURRENT AMPS 3 x 415V
③	2750	595	1.13
②	2200	415	0.64
①	1450	220	0.67

Maximum permissible power consumption:  
All motors are suitable for the values shown plus 10 per cent overload.

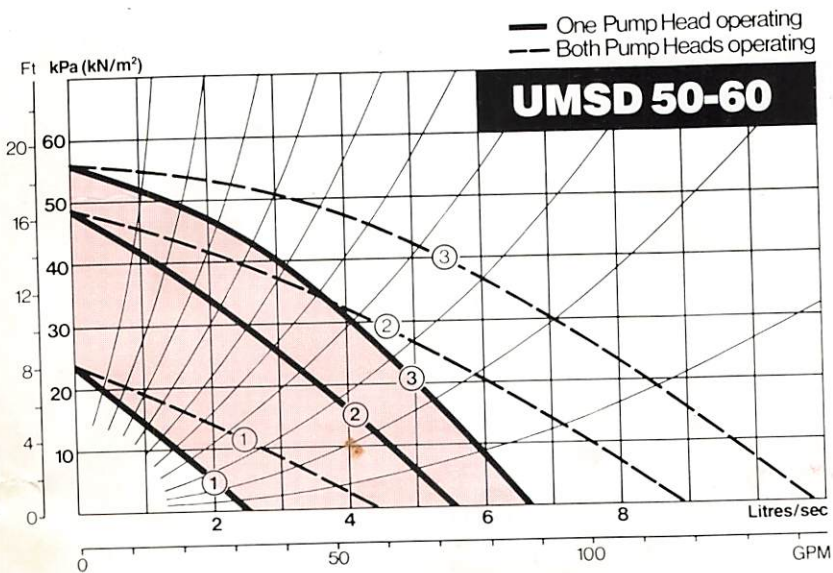

## ELECTRICAL DATA FOR ONE HEAD IN OPERATION

SPEED	R.P.M.	INPUT POWER WATTS	FULL LOAD CURRENT AMPS 3 x 415V
③	1380	450	1.00
②	1180	310	0.55
①	650	115	0.23

## ELECTRICAL DATA FOR EACH HEAD WHEN BOTH ARE OPERATING IN PARALLEL

SPEED	R.P.M.	INPUT POWER WATTS	FULL LOAD CURRENT AMPS 3 x 415V
③	1380	420	0.96
②	1180	295	0.50
①	650	115	0.20

Maximum permissible power consumption:  
All motors are suitable for the values shown plus 10 per cent overload.

# SINGLE HEAD MODELS 3 x 415V 50Hz

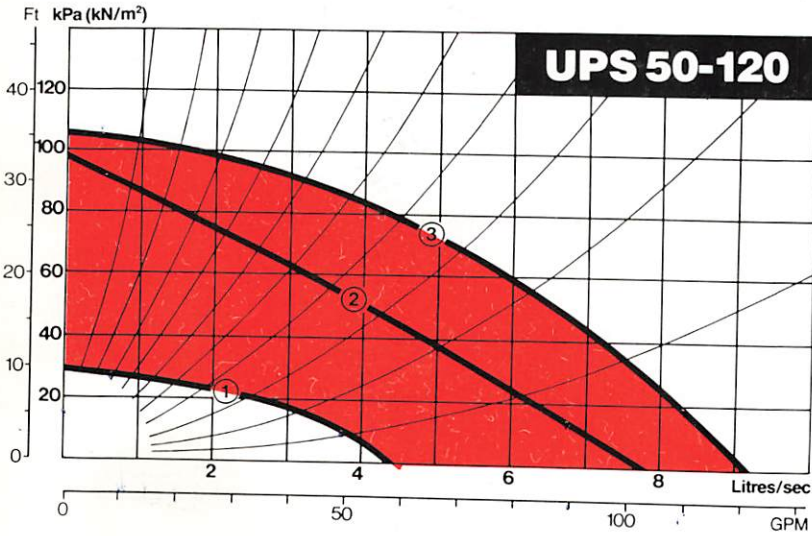

## ELECTRICAL DATA

SPEED	R.P.M.	INPUT POWER WATTS	FULL LOAD CURRENT AMPS 3 x 415V
③	2760	980	1.65
②	2250	750	1.15
①	1450	280	0.92

Maximum permissible power consumption:  
All motors are suitable for the values shown plus 10 per cent overload.

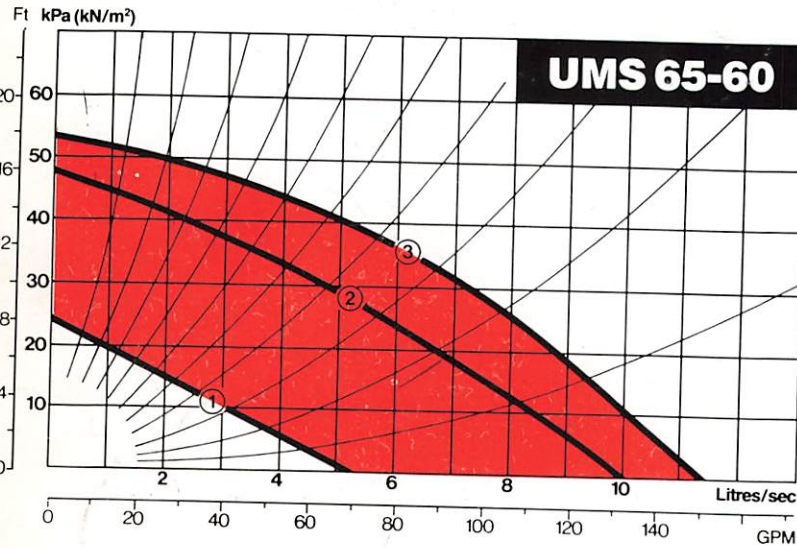

## ELECTRICAL DATA

SPEED	R.P.M.	INPUT POWER WATTS	FULL LOAD CURRENT AMPS 3 x 415V
③	1400	580	1.42
②	1220	420	0.73
①	720	180	0.32

Maximum permissible power consumption:  
All motors are suitable for the values shown plus 10 per cent overload.

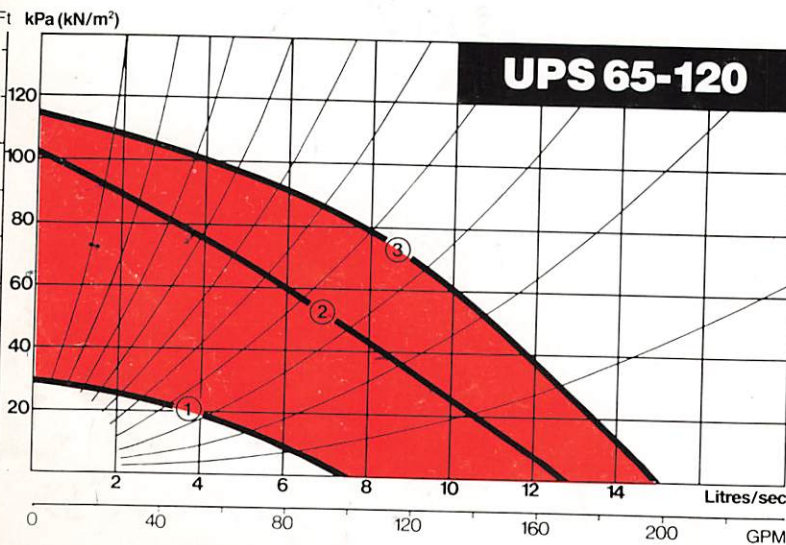

## ELECTRICAL DATA

SPEED	R.P.M.	INPUT POWER WATTS	FULL LOAD CURRENT AMPS 3 x 415V
③	2800	1450	2.47
②	2350	1120	1.80
①	1450	325	1.24

Maximum permissible power consumption:  
All motors are suitable for the values shown plus 10 per cent overload.

# TWIN HEAD MODELS 3 x 415V 50Hz

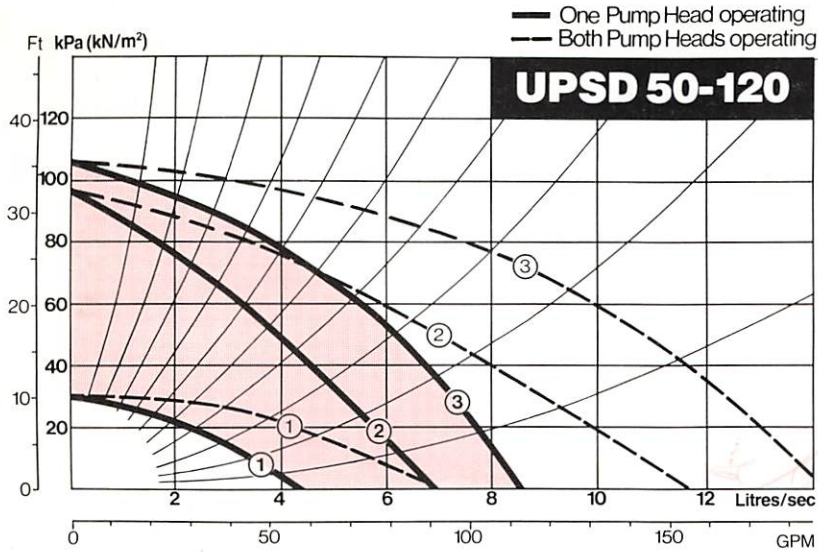

## ELECTRICAL DATA FOR ONE HEAD IN OPERATION

SPEED	R.P.M.	INPUT POWER WATTS	FULL LOAD CURRENT AMPS 3 × 415V
③	2760	980	1.65
②	2250	750	1.15
①	1450	280	0.92

## ELECTRICAL DATA FOR EACH HEAD WHEN BOTH ARE OPERATING IN PARALLEL

SPEED	R.P.M.	INPUT POWER WATTS	FULL LOAD CURRENT AMPS 3 × 415V
③	2760	970	1.65
②	2250	720	1.15
①	1450	260	0.92

Maximum permissible power consumption:  
All motors are suitable for the values shown plus 10 per cent overload.

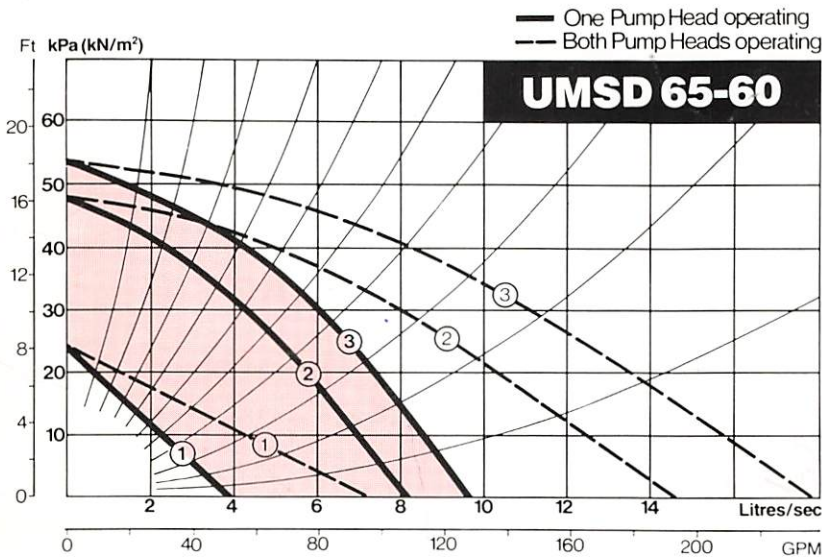

## ELECTRICAL DATA FOR ONE HEAD IN OPERATION

SPEED	R.P.M.	INPUT POWER WATTS	FULL LOAD CURRENT AMPS 3 × 415V
③	1400	580	1.42
②	1220	420	0.73
①	720	180	0.32

## ELECTRICAL DATA FOR EACH HEAD WHEN BOTH ARE OPERATING IN PARALLEL

SPEED	R.P.M.	INPUT POWER WATTS	FULL LOAD CURRENT AMPS 3 × 415V
③	1400	550	1.35
②	1220	400	0.72
①	720	170	0.59

Maximum permissible power consumption:  
All motors are suitable for the values shown plus 10 per cent overload.

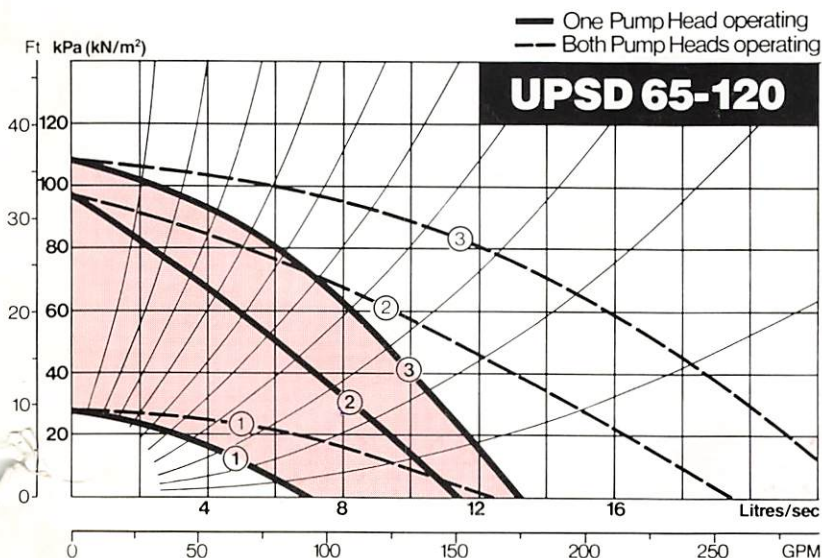

## ELECTRICAL DATA FOR ONE HEAD IN OPERATION

SPEED	R.P.M.	INPUT POWER WATTS	FULL LOAD CURRENT AMPS 3 × 415V
③	2800	1450	2.47
②	2350	1120	1.80
①	1450	325	1.24

## ELECTRICAL DATA FOR EACH HEAD WHEN BOTH ARE OPERATING IN PARALLEL

SPEED	R.P.M.	INPUT POWER WATTS	FULL LOAD CURRENT AMPS 3 × 415V
③	2800	1380	2.29
②	2350	1100	1.74
①	1450	330	1.22

Maximum permissible power consumption:  
All motors are suitable for the values shown plus 10 per cent overload.

# SINGLE HEAD MODELS 3 x 415V 50Hz

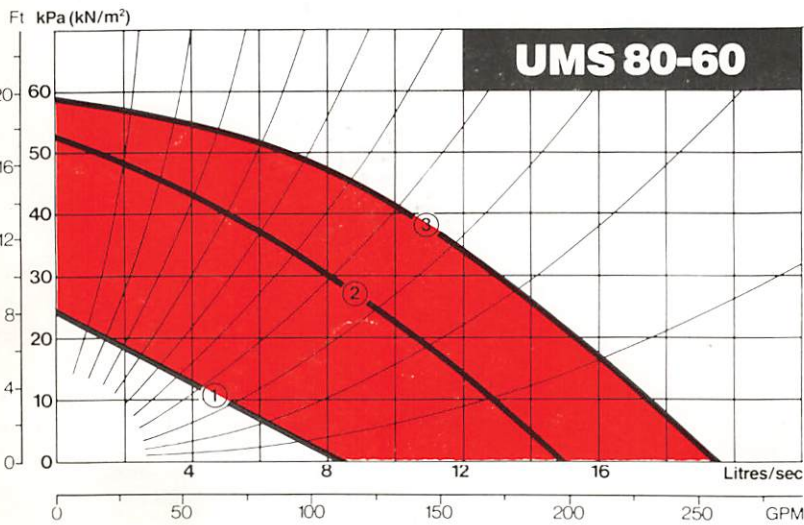

## ELECTRICAL DATA

SPEED	R.P.M.	INPUT POWER WATTS	FULL LOAD CURRENT AMPS 3 x 415V
③	1400	950	2.02
②	1180	680	1.24
①	750	250	0.46

Maximum permissible power consumption:  
All motors are suitable for the values shown plus 10 per cent overload.

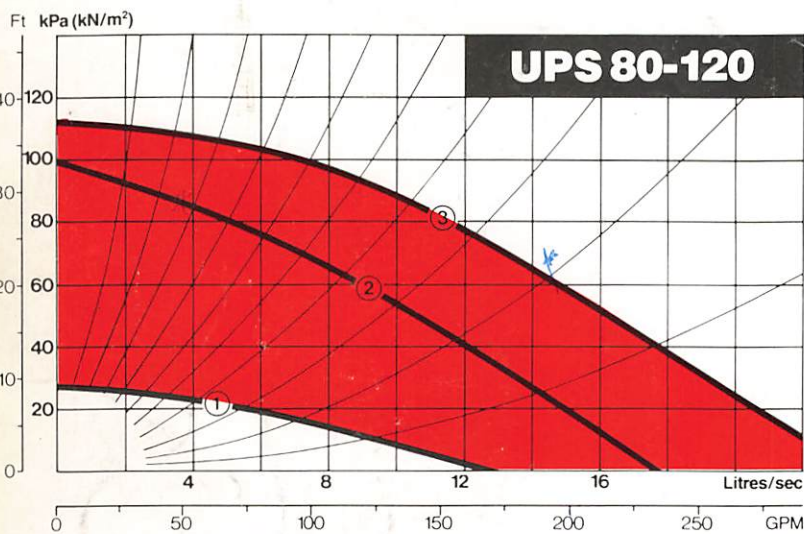

## ELECTRICAL DATA

SPEED	R.P.M.	INPUT POWER WATTS	FULL LOAD CURRENT AMPS 3 x 415V
③	2800	2200	3.66
②	2400	1700	2.70
①	1470	490	1.83

Maximum permissible power consumption:  
All motors are suitable for the values shown plus 10 per cent overload.

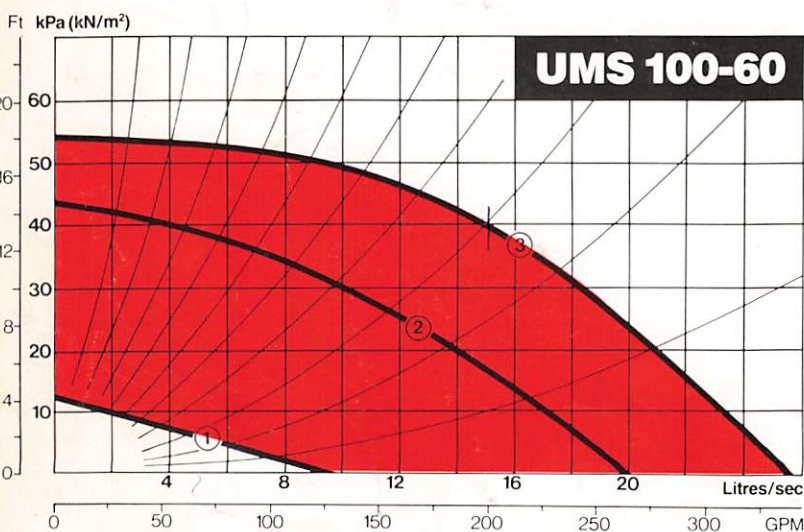

## ELECTRICAL DATA

SPEED	R.P.M.	INPUT POWER WATTS	FULL LOAD CURRENT AMPS 3 x 415V
③	1370	1400	3.00
②	1100	930	1.70
①	550	285	0.59

Maximum permissible power consumption:  
All motors are suitable for the values shown plus 10 per cent overload.

# TABLE OF DIMENSIONS AND WEIGHTS

## Single Pump UMS/UPS

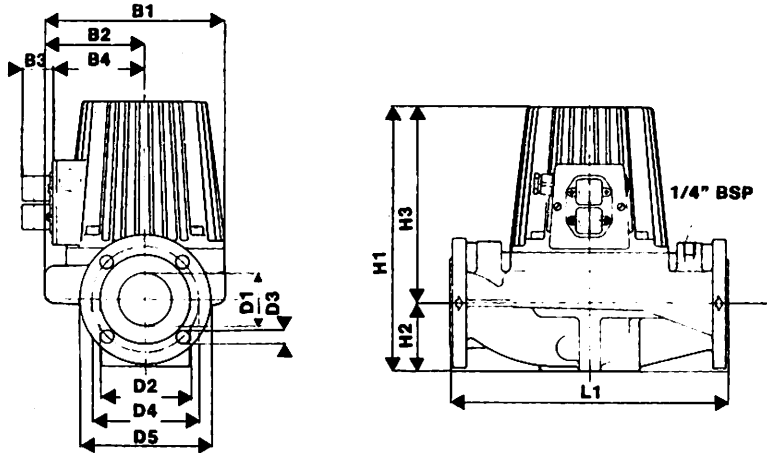

PUMP TYPE	FLANGE SIZE			DIMENSION														WEIGHT NETT WITH FLANGES Kg.
	Working pressure		BSP	B1	B2	B3	B4	D1	D2	D3	No. D3	D4	D5	H1	H2	H3	L1	
	BAR	PSI																
	mm	mm	mm	mm	mm	mm	mm	mm	mm	mm	mm	mm	mm	mm	mm	mm		
UPS 40/60	6	87	1½"	165	90	38	95	42	80	14	4	100	130	271	67	204	250	17.0
	4	56	2"															
UPS 40/120	6	87	1½"	165	90	38	95	42	80	14	4	100	130	271	67	204	250	18.0
	4	56	2"															
UMS 50/60	6	87	2"	206	104	38	115	50	90	14	4	110	140	260	73	187	280	25.4
UPS 50/120	6	87	2"	206	104	38	115	50	90	14	4	110	140	260	73	187	280	25.4
UMS 65/60	6	87	2½"	226	124	38	115	65	110	14	4	130	160	327	83	244	340	32.7
UPS 65/120	6	87	2½"	226	124	38	115	65	110	14	4	130	160	327	83	244	340	34.7
UMS 80/60	6	87	3"	234	130	38	115	80	128	18	4	150	190	343	98	245	360	40.0
UPS 80/120	6	87	3"	234	130	38	115	80	128	18	4	150	190	343	98	245	360	41.5
UMS 100/60	6	87	4"	288	165	38	115	100	148	18	4	170	210	395	110	285	450	52.0

## Twin Pump UMSD/UPSD

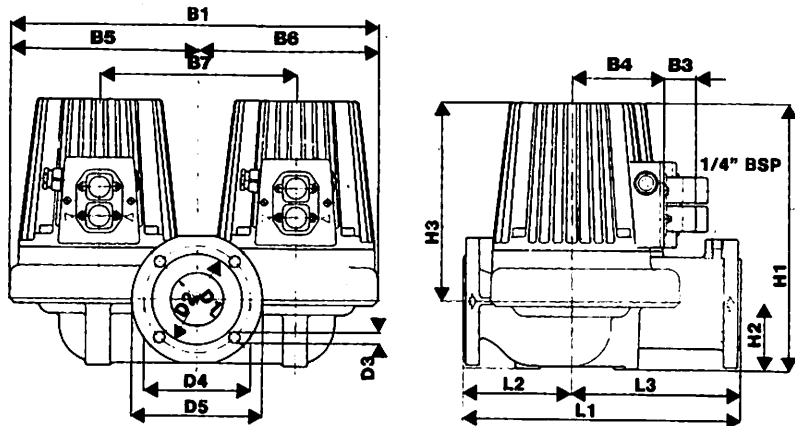

PUMP TYPE	FLANGE SIZE			DIMENSION															WEIGHT NETT WITH FLANGES Kg.			
	Working pressure		BSP	B1	B3	B4	B5	B6	B7	D1	D2	D3	No. D3	D4	D5	H1	H2	H3		L1	L2	L3
	BAR	PSI																				
	mm	mm	mm	mm	mm	mm	mm	mm	mm	mm	mm	mm	mm	mm	mm	mm	mm	mm		mm	mm	mm
UPSD 40/60	6	87	1½"	366	38	95	184	182	200	42	80	14	4	100	130	272	68	204	250	98	152	29.0
	4	56	2"																			
UPSD 40/120	6	87	1½"	366	38	95	184	182	200	42	80	14	4	100	130	272	68	204	250	98	152	31.0
	4	56	2½"																			
UMSD 50/60	6	87	2"	440	38	115	220	220	240	50	90	14	4	110	140	260	73	187	280	120	160	43.4
UPSD 50/120	6	87	2"	440	38	115	220	220	240	50	90	14	4	110	140	260	73	187	280	120	160	43.4
UMSD 65/60	6	87	2½"	454	38	115	230	224	240	65	110	14	4	130	160	327	83	244	340	140	200	55.7
UPSD 65/120	6	87	2½"	454	38	115	230	224	240	65	110	14	4	130	160	327	83	244	340	140	200	59.7
UMSD 80/60	6	87	3"	468	38	115	236	228	240	80	128	18	4	150	190	337	92	245	360	145	215	65.0
UPSD 80/120	6	87	3"	468	38	115	236	228	240	80	128	18	4	150	190	337	92	245	360	145	215	67.0
UMSD 100/60	6	87	4"	596	38	115	306	290	300	100	148	18	4	170	210	395	110	285	450	170	280	69.0

# BASE MOUNTING

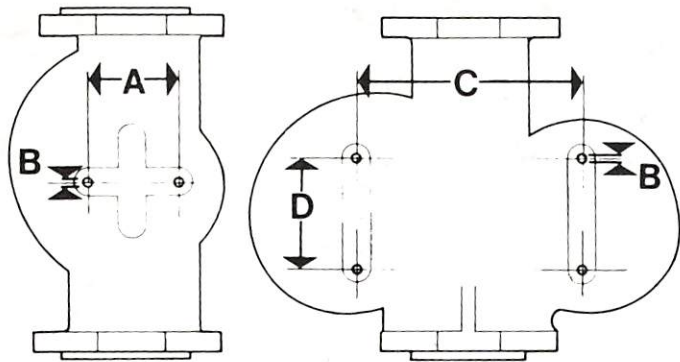

\* Tapped holes are provided on the underside of all Multi-Speed pumps, which can be used for mounting brackets if required.

## SINGLE HEAD MODELS:

MODEL	A mm	B(mm)	
		Dia	Depth
UPS 40-60	96	M12	18
UPS 40-120	96	M12	18
UMS 50-60	96	M12	18
UPS 50-120	96	M12	18
UMS 65-60	96	M12	18
UPS 65-120	96	M12	18
UMS 80-60	96	M12	18
UPS 80-120	96	M12	18
UMS 100-60	144	M16	25

## TWIN HEAD MODELS:

MODEL	B(mm)		C mm	D mm
	*Dia	Depth		
UPSD 40-60	M12	18	200	96
UPSD 40-120	M12	18	200	96
UMSD 50-60	M12	18	240	120
UPSD 50-120	M12	18	240	120
UMSD 65-60	M12	18	240	120
UPSD 65-120	M12	18	240	120
UMSD 80-60	M12	18	240	120
UPSD 80-120	M12	18	240	120
UMSD 100-60	M16	25	280	144

# MOTOR PROTECTION

- 1) All Multi-Speed pumps must be connected to a starter which must incorporate overload protection and, for three-phase models, the starter must incorporate 'single-phasing' protection.
- 2) An automatically re-setting heat-sensitive switch (thermo-contact) is built into the motor windings on all Multi-Speed circulators and is connected between terminals 5 and 6. This Thermo-Contact should be connected into the control circuit of a contactor-type starter, in series with the overload contact and the coil. It is preferable that the thermo-contact is utilized on all installations, since this gives double protection against overload and overheating (e.g. - installations

- where the combinations of water and ambient temperatures could exceed the design limits). It is essential that the thermo-contact is connected on installations which incorporate automatic speed change, since the operating current will alter when the speed is changed. It is impractical to 're-set' the starter overload with each speed change.
- 3) The thermo-contact will not switch the motor current direct, but must be connected into the control circuit of a contactor starter.
  - 4) If the thermo-contact is not incorporated the overload unit in the starter must be set to the same value as the operating current of the speed on which the pump will operate.

# MULTI-SPEED PLUGS

Each pump head is supplied with a double multi plug marked 2 and 3. The speed and performance of the pump head is altered by reversing the position of the plug in the socket of the terminal box. Speed 1 plug is not normally supplied, but can be supplied as an extra if necessary.

### Automatic speed change

Also available is a multi-core cable and plug which enables automatic control of all three pump speeds to be effected from the main system control panel. This feature is ideally suited to energy-conscious control systems. A separate leaflet giving wiring details is available on request.

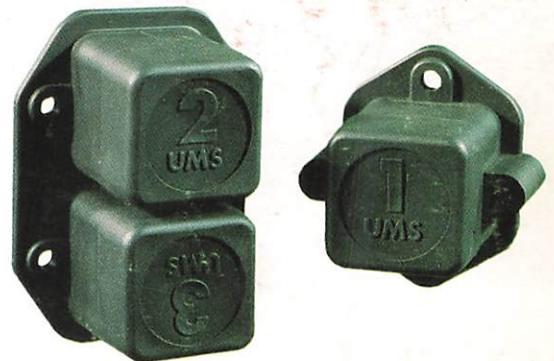

# ADVANTAGES OF GRUNDFOS TWIN HEAD PUMPS

Grundfos Twin Head pumps provide a neat, compact and space saving installation where duty and standby operation is required, while only taking up the identical flange to flange space of its single head counterpart (see diagram). A built-in non-return valve in the pump discharge port prevents reverse circulation through the stationary pump and obviates the need for manual valve opening or closing. When the duty pump is switched off and the standby pump is brought into use, the non-return valve will automatically change its position. This design eliminates unnecessary isolating and non-return valves, yet still enables pump head replacement to be carried out in a matter of minutes without serious interruption to the operation of the heating system. Blanking flanges can be supplied for this purpose at a small extra cost.

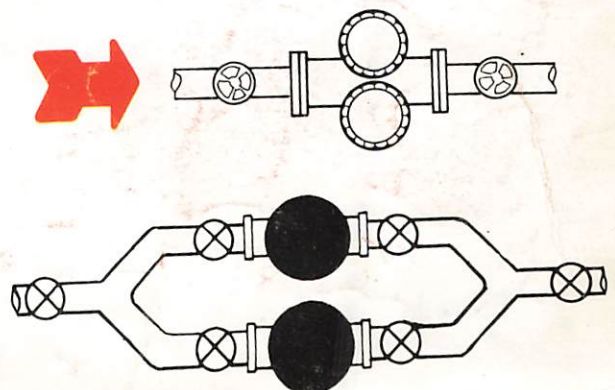

# TWIN HEAD MODELS 3 x 415V 50Hz

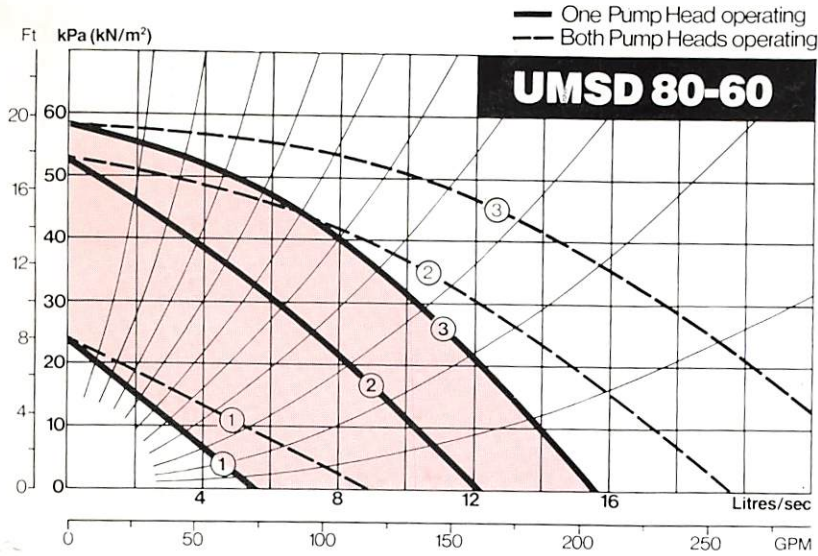

## ELECTRICAL DATA FOR ONE HEAD IN OPERATION

SPEED	R.P.M.	INPUT POWER WATTS	FULL LOAD CURRENT AMPS 3 × 415V
③	1400	950	2.02
②	1180	680	1.24
①	750	250	0.46

## ELECTRICAL DATA FOR EACH HEAD WHEN BOTH ARE OPERATING IN PARALLEL

SPEED	R.P.M.	INPUT POWER WATTS	FULL LOAD CURRENT AMPS 3 × 415V
③	1400	775	1.79
②	1180	570	1.03
①	750	225	0.44

Maximum permissible power consumption: All motors are suitable for the values shown plus 10 per cent overload.

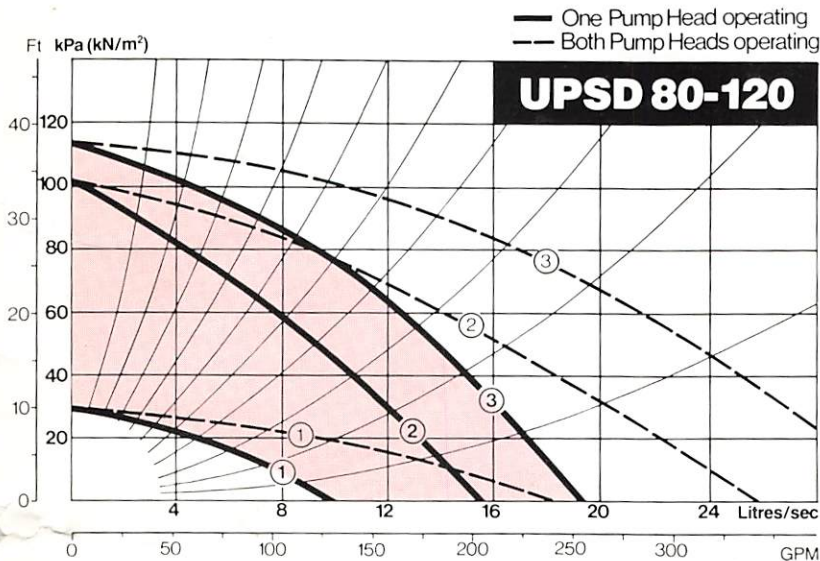

## ELECTRICAL DATA FOR ONE HEAD IN OPERATION

SPEED	R.P.M.	INPUT POWER WATTS	FULL LOAD CURRENT AMPS 3 × 415V
③	2800	2200	3.66
②	2400	1700	2.70
①	1470	490	1.83

## ELECTRICAL DATA FOR EACH HEAD WHEN BOTH ARE OPERATING IN PARALLEL

SPEED	R.P.M.	INPUT POWER WATTS	FULL LOAD CURRENT AMPS 3 × 415V
③	2800	1880	3.16
②	2400	1540	2.36
①	1470	440	1.76

Maximum permissible power consumption: All motors are suitable for the values shown plus 10 per cent overload.

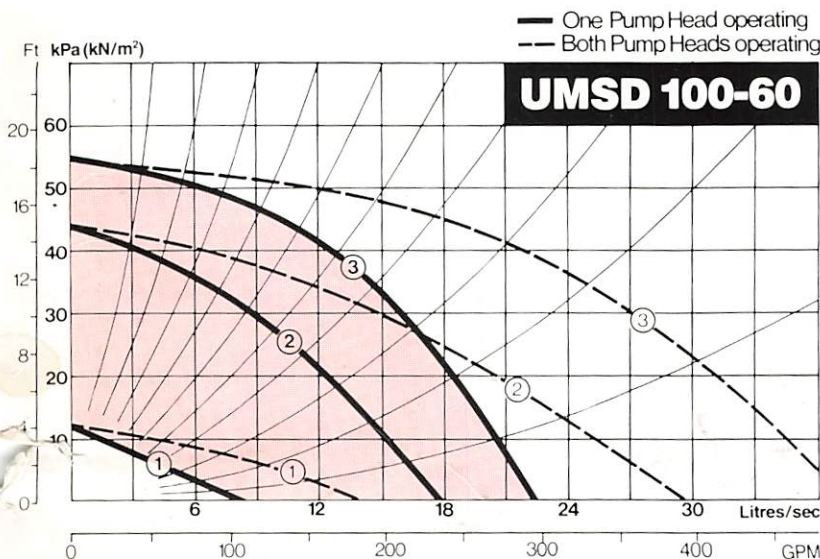

## ELECTRICAL DATA FOR ONE HEAD IN OPERATION

SPEED	R.P.M.	INPUT POWER WATTS	FULL LOAD CURRENT AMPS 3 × 415V
③	1370	1400	3.00
②	1100	930	1.70
①	550	285	0.59

## ELECTRICAL DATA FOR EACH HEAD WHEN BOTH ARE OPERATING IN PARALLEL

SPEED	R.P.M.	INPUT POWER WATTS	FULL LOAD CURRENT AMPS 3 × 415V
③	1370	1390	2.95
②	1100	920	1.67
①	550	285	0.58

Maximum permissible power consumption: All motors are suitable for the values shown plus 10 per cent overload.

# INSTALLATION

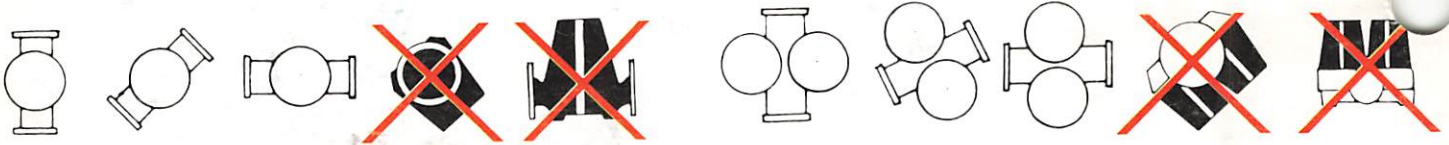

ALL MULTI-SPEED PUMPS MUST BE INSTALLED WITH THE PUMP SHAFT HORIZONTAL OR SLIGHTLY ABOVE, AS THIS IMPROVES AIR PURGING AND REDUCES THE LOAD ON THE PUMP THRUST BEARING. THE PUMPS MUST NEVER BE INSTALLED WITH THE SHAFT

IN A VERTICAL PLANE, NOR, WHEN IN A HORIZONTAL PLANE, MUST THE PUMP SHAFT FALL BELOW THE HORIZONTAL, EVEN BY A FEW DEGREES, AS THIS MAY CAUSE PREMATURE WEAR OF THE TOP BEARING AND SHAFT.

# OPERATING

All models are suitable for maximum system pressures of 6 bars (85 psi) and maximum system water temperatures of 120°C. UPS 40 pumps with 2" flanges have 4 bar rating.

### Maximum Permissible Operating Temperatures

System Water Temp °C	120	110	105	100	90	80
Air Temp °C	20	30	40	50	60	70

# SITING THE PUMP

- 1) To avoid sediment, do not fit the pump in lowest point of system.
- 2) Fit isolating valves on either side of the pump.
- 3) To prevent noise, avoid sharp bends either side of the pump.
- 4) Position the motor away from heat sources and allow access for removing pump head from base.
- 5) Always try to ensure that the terminal box is not adjacent to hot surfaces, and that the multi-plug is readily accessible for adjustment of pump speed.
- 6) In non-pressurised systems, position the pump so that it neither pumps over into feed/expansion tank, nor sucks air down the vent pipe. Generally this means fitting the pump in the flow pipe, with the vent on the inlet side of the pump.

- 7) In pressurised systems, the pump can be fitted in flow or return pipes as required.
- 8) In systems, where all the flow can be stopped while the pump is still running, e.g. systems fitted with thermostatic valves, a by-pass should be fitted, between flow and return lines, to ensure water flow through the pump at all times (approx. 7.5% of maximum pump capacity).
- 9) Ensure the pump is not stressed by the pipework and that the pipework is properly supported either side of the pump.

### Twin Head Models

For twin head models installed in horizontal pipes it is recommended that an automatic air vent (1/8 inch BSP) is fitted as shown.

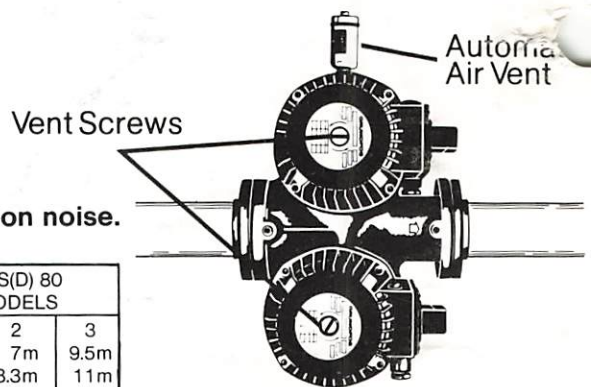

### Approximate Minimum Inlet Pressure required to avoid cavitation noise.

Selected Pump Speed	All UMS(D) MODELS			All UPS(D) 40, UPS(D) 50 and UPS(D) 65 MODELS			UPS(D) 80 MODELS		
	1	2	3	1	2	3	1	2	3
Water Temp. 71°C (160°F)	0.75m	2m	2.7m	1.5m	4m	5.5m	2.5m	7m	9.5m
Water Temp. 82°C (180°F)	1m	2.6m	3.5m	2m	5.3m	7m	3m	8.3m	11m

# GRUNDFOS



Grundfos Pumps Ltd. Head Office: Grovebury Road, Leighton Buzzard, Beds. LU7 8TL. Tel (0525) 374876. Telex 825544.  
Northern Area Sales Office: Gawsworth Court, Risley Road, Risley, Warrington, Cheshire. Tel: Padgate (0925) 813300. Telex 628162.

MS 1/85

It is the continuing policy of Grundfos to develop and improve our products, and we reserve the right to amend prices and specification without prior notice.