

UP/UPS GLANDLESS IN-LINE CIRCULATORS

For hot water circulation in light commercial heating applications.



GRUNDFOS



THE INSTALLER'S BEST CHOICE FOR NEW OR REPLACEMENT HEATING CIRCULATORS

- * GLANDLESS HEATING CIRCULATORS FOR PIPELINE MOUNTING.
- * STAINLESS STEEL COMPONENTS FOR HIGH EFFICIENCY AND RESISTANCE TO CORROSION.
- * VARIABLE DUTY.
- * FLOWS UP TO 2.6 LITRES/SEC FOR HEATING DUTIES UP TO 400,000 BTUS/HR.
- * FRICTIONAL RESISTANCES UP TO 70kN/m².
- * ALL PUMPS SUPPLIED WITH FITTINGS.
- * PUMP HOUSING FLANGED TO BS4504 1969 TABLE 6/11 ON UP(D)/UPS(D) 40 MODELS.
- * CHOICE OF 1" OR 1 1/4" BSPF UNION FITTINGS ON UPS 25 MODELS.
- * FIVE SINGLE AND TWO TWIN HEAD 1 PHASE MODELS.
- * TWO SINGLE AND TWO TWIN HEAD 3 PHASE MODELS.
- * WATER TEMPERATURES UP TO 110°C.
- * FLAP VALVE FITTED AS STANDARD ON TWIN HEAD MODELS.

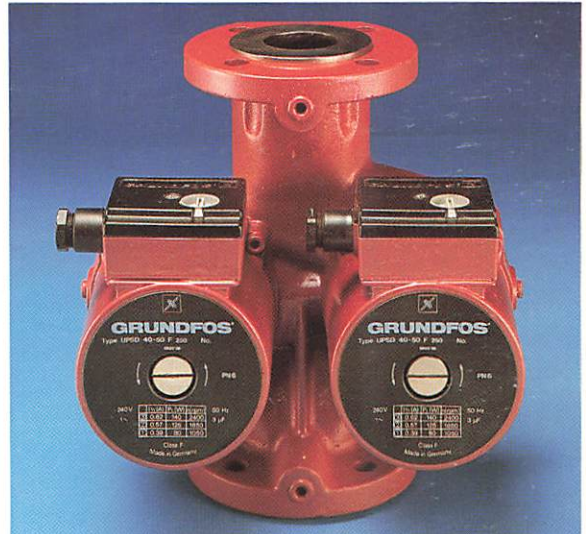
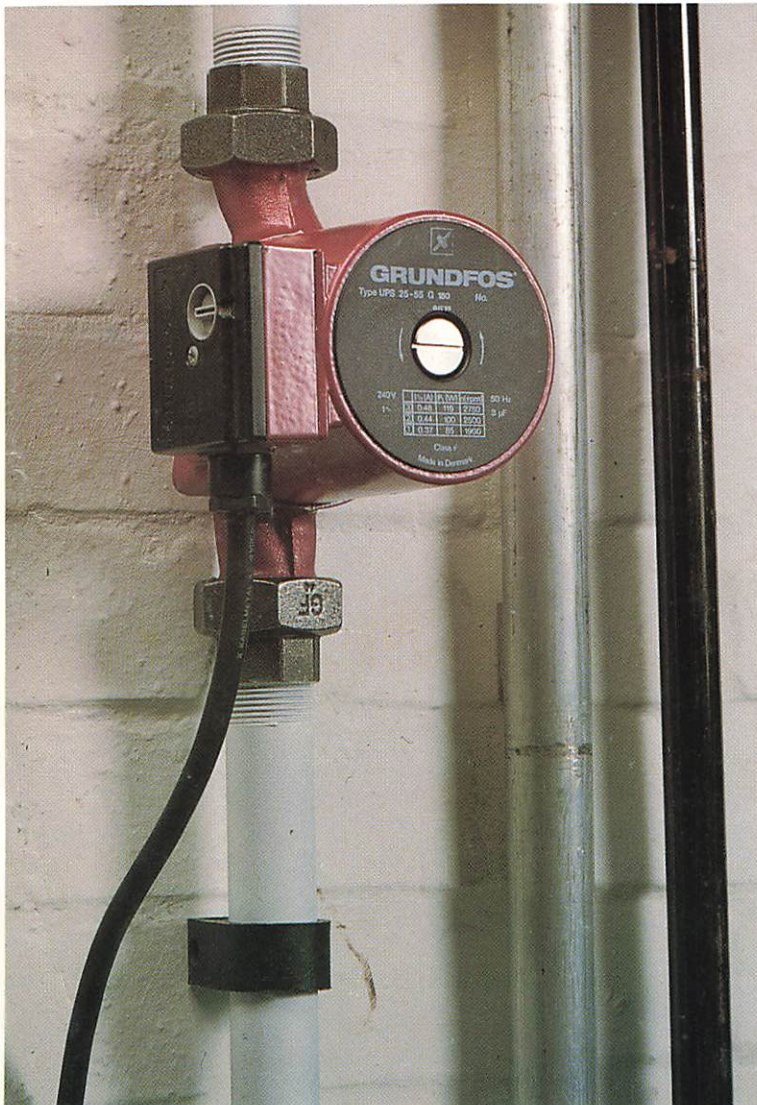

1 × 240V 50Hz MODELS

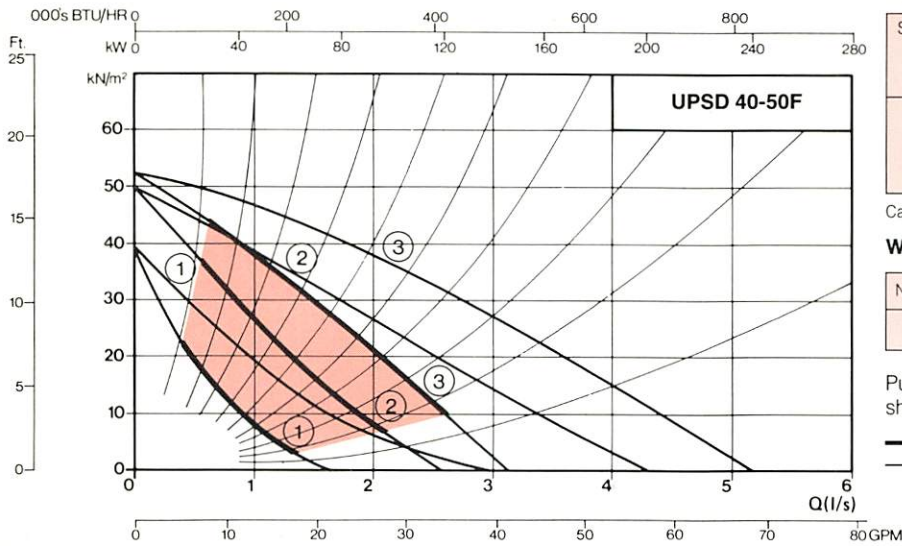

ELECTRICAL DATA

| SPEED | RPM | INPUT POWER WATTS | FULL LOAD CURRENT AMPS 1 × 240 VOLT | LOCKED ROTOR CURRENT AMPS |
|-------|------|-------------------|--|---------------------------|
| 3 | 2400 | 140 | 0.62 | 0.93 |
| 2 | 1650 | 125 | 0.57 | 0.66 |
| 1 | 1050 | 80 | 0.39 | 0.43 |

Capacitor Rating 3 μ F

WEIGHTS

| NET WEIGHT KG | GROSS WEIGHT KG | SHIPPING VOLUME M ³ |
|---------------|-----------------|--------------------------------|
| 13.6 | 14.0 | 0.0126 |

Pump selection should be within the shaded area, for optimum performance.

— One pump head operating
- - - Both pump heads operating

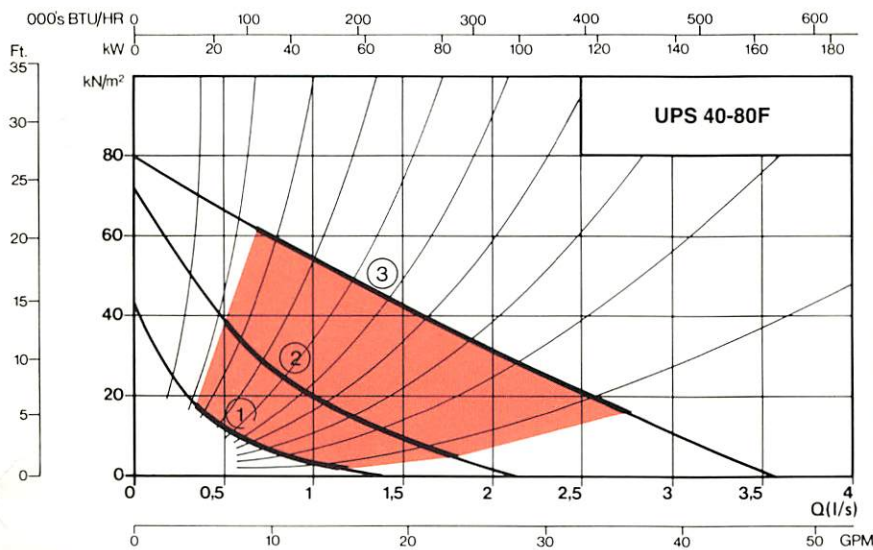

ELECTRICAL DATA

| SPEED | RPM | INPUT POWER WATTS | FULL LOAD CURRENT AMPS 1 × 240 VOLT | LOCKED ROTOR CURRENT AMPS |
|-------|------|-------------------|--|---------------------------|
| 3 | 2450 | 250 | 1.0 | 1.52 |
| 2 | 1700 | 215 | 0.91 | 1.10 |
| 1 | 1100 | 145 | 0.62 | 0.70 |

Capacitor Rating 5 μ F

WEIGHTS

| NET WEIGHT KG | GROSS WEIGHT KG | SHIPPING VOLUME M ³ |
|---------------|-----------------|--------------------------------|
| 7.2 | 7.6 | 0.0122 |

Pump selection should be within the shaded area, for optimum performance.

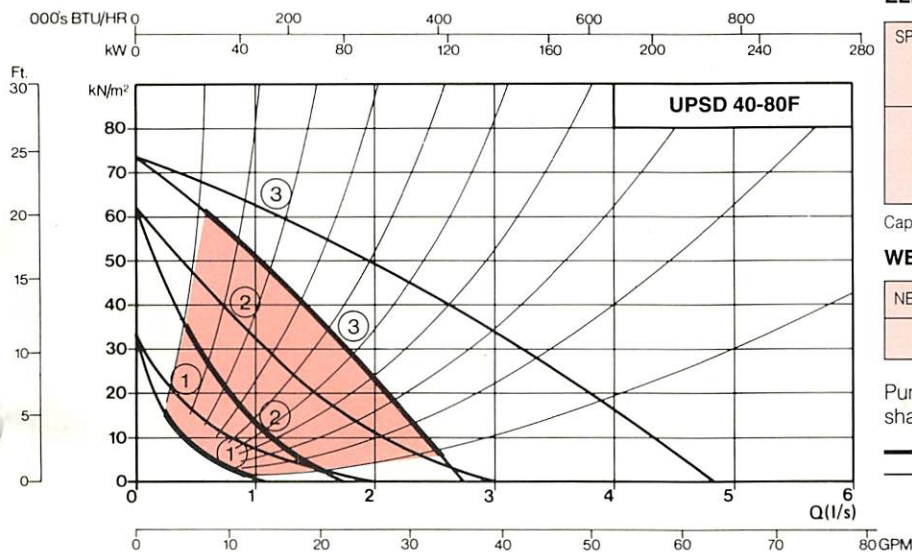

ELECTRICAL DATA

| SPEED | RPM | INPUT POWER WATTS | FULL LOAD CURRENT AMPS 1 × 240 VOLT | LOCKED ROTOR CURRENT AMPS |
|-------|------|-------------------|--|---------------------------|
| 3 | 2450 | 250 | 1.0 | 1.52 |
| 2 | 1700 | 215 | 0.91 | 1.10 |
| 1 | 1100 | 145 | 0.62 | 0.70 |

Capacitor Rating 5 μ F

WEIGHTS

| NET WEIGHT KG | GROSS WEIGHT KG | SHIPPING VOLUME M ³ |
|---------------|-----------------|--------------------------------|
| 13.6 | 14.0 | 0.0126 |

Pump selection should be within the shaded area, for optimum performance.

— One pump head operating
- - - Both pump heads operating

3 × 415V 50Hz MODELS

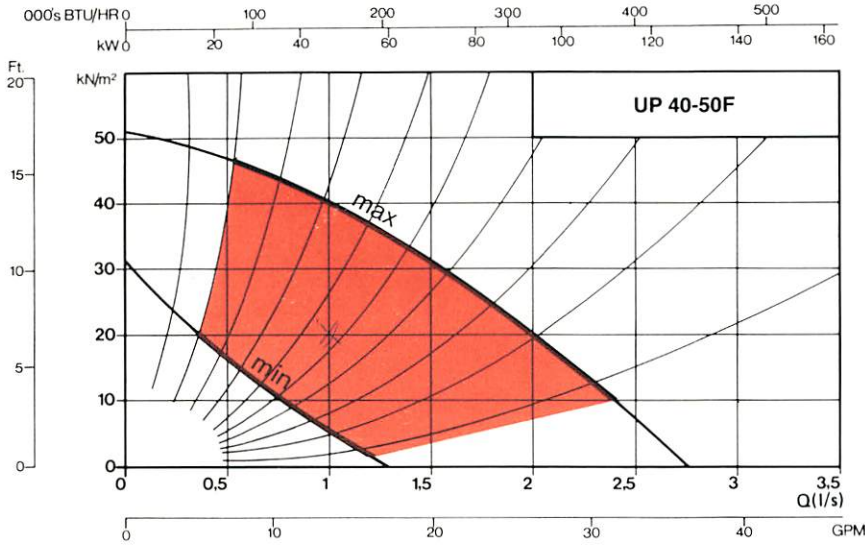

ELECTRICAL DATA

| RPM | INPUT POWER WATTS | FULL LOAD CURRENT AMPS 3 × 415 VOLT | LOCKED ROTOR CURRENT AMPS |
|------|-------------------|-------------------------------------|---------------------------|
| 2700 | 160 | 0.29 | 0.86 |

WEIGHTS

| NET WEIGHT KG | GROSS WEIGHT KG | SHIPPING VOLUME M ³ |
|---------------|-----------------|--------------------------------|
| 7.4 | 7.8 | 0.0122 |

Pump selection should be within the shaded area, for optimum performance.

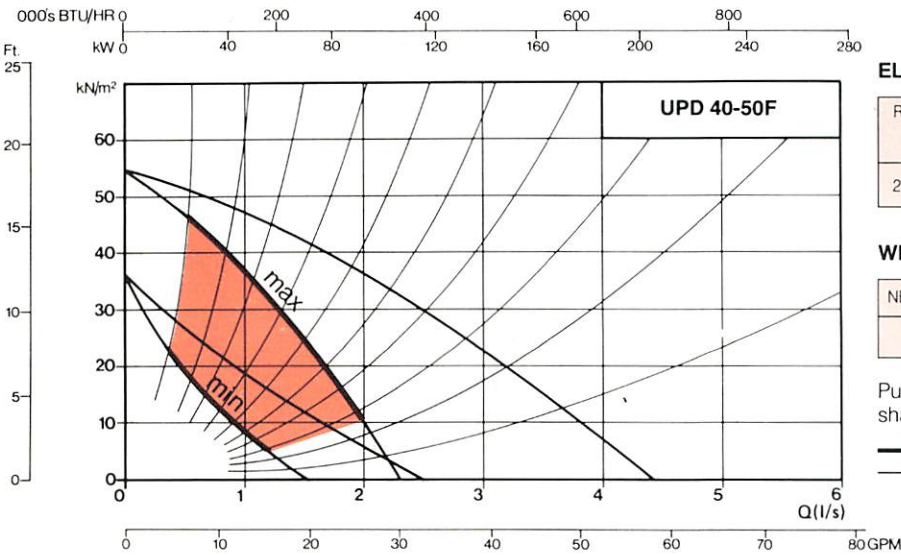

ELECTRICAL DATA

| RPM | INPUT POWER WATTS | FULL LOAD CURRENT AMPS 3 × 415 VOLT | LOCKED ROTOR CURRENT AMPS |
|------|-------------------|-------------------------------------|---------------------------|
| 2700 | 160 | 0.29 | 0.86 |

WEIGHTS

| NET WEIGHT KG | GROSS WEIGHT KG | SHIPPING VOLUME M ³ |
|---------------|-----------------|--------------------------------|
| 13.7 | 14.1 | 0.0126 |

Pump selection should be within the shaded area, for optimum performance.

- One pump head operating
- Both pump heads operating

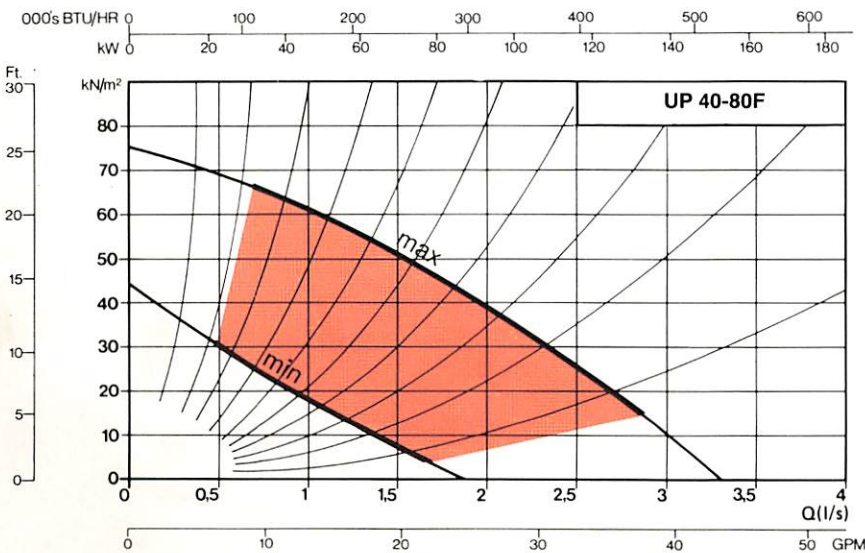

ELECTRICAL DATA

| RPM | INPUT POWER WATTS | FULL LOAD CURRENT AMPS 3 × 415 VOLT | LOCKED ROTOR CURRENT AMPS |
|------|-------------------|-------------------------------------|---------------------------|
| 2650 | 280 | 0.50 | 1.30 |

WEIGHTS

| NET WEIGHT KG | GROSS WEIGHT KG | SHIPPING VOLUME M ³ |
|---------------|-----------------|--------------------------------|
| 7.4 | 7.8 | 0.0122 |

Pump selection should be within the shaded area, for optimum performance.

VERSATILE, ENERGY EFFICIENT RANGE

The new range of GRUNDFOS Light Commercial Circulators now provide the installer with a more versatile energy efficient range of pumps whilst retaining the capability to cater for heating duties up to 400,000 btus/hr.

IDEAL FOR NEW OR REPLACEMENT WORK

Designed for quick and neat fitting, the range covers pipe sizes of 1", 1 1/4", 1 1/2" and 2" and is completely interchangeable with previous models, making installation and replacement really easy.

COMPREHENSIVE PERFORMANCE RANGE

The Light Commercial range consists of seven single head and four twin head models, designed to cater for the majority of heating requirements in the Light Commercial market place.

BUILT FOR LONG LIFE

Like all GRUNDFOS pumps, these models incorporate precision built components for maximum efficiency and sustained performance over many years operation. Components like fabricated stainless steel impellers and rotor cans for resistance to corrosion and smooth operation, together with water lubricated hard wearing ceramics for pump bearings. Add to this our reputation for first class after sales service, and you can see why GRUNDFOS is the installer's number one choice in circulators.

GRUNDFOS TWIN HEAD PUMPS — THE SPACE SAVERS

Grundfos Twin Head pumps provide a neat, compact and space saving installation where duty and standby operation is required, while only taking up the identical flange to flange space of its single head counterpart. A built-in non-return valve in the pump discharge port prevents reverse circulation through the stationary pump and obviates the need for manual valve opening or closing. When the duty pump is switched off and the standby pump is brought into use, the non-return valve will automatically change its position. This design eliminates unnecessary isolating and non-return valves, yet still enables pump head replacement to be carried out in a matter of minutes without serious interruption to the operation of the heating system. Blanking flanges can be supplied for this purpose at a small extra cost.

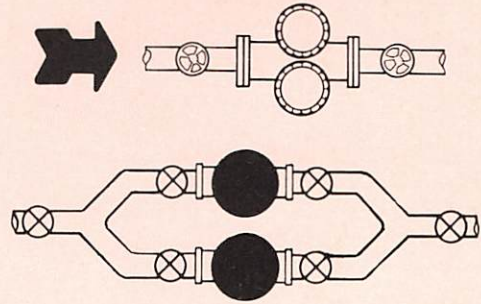

PERFORMANCE RANGE

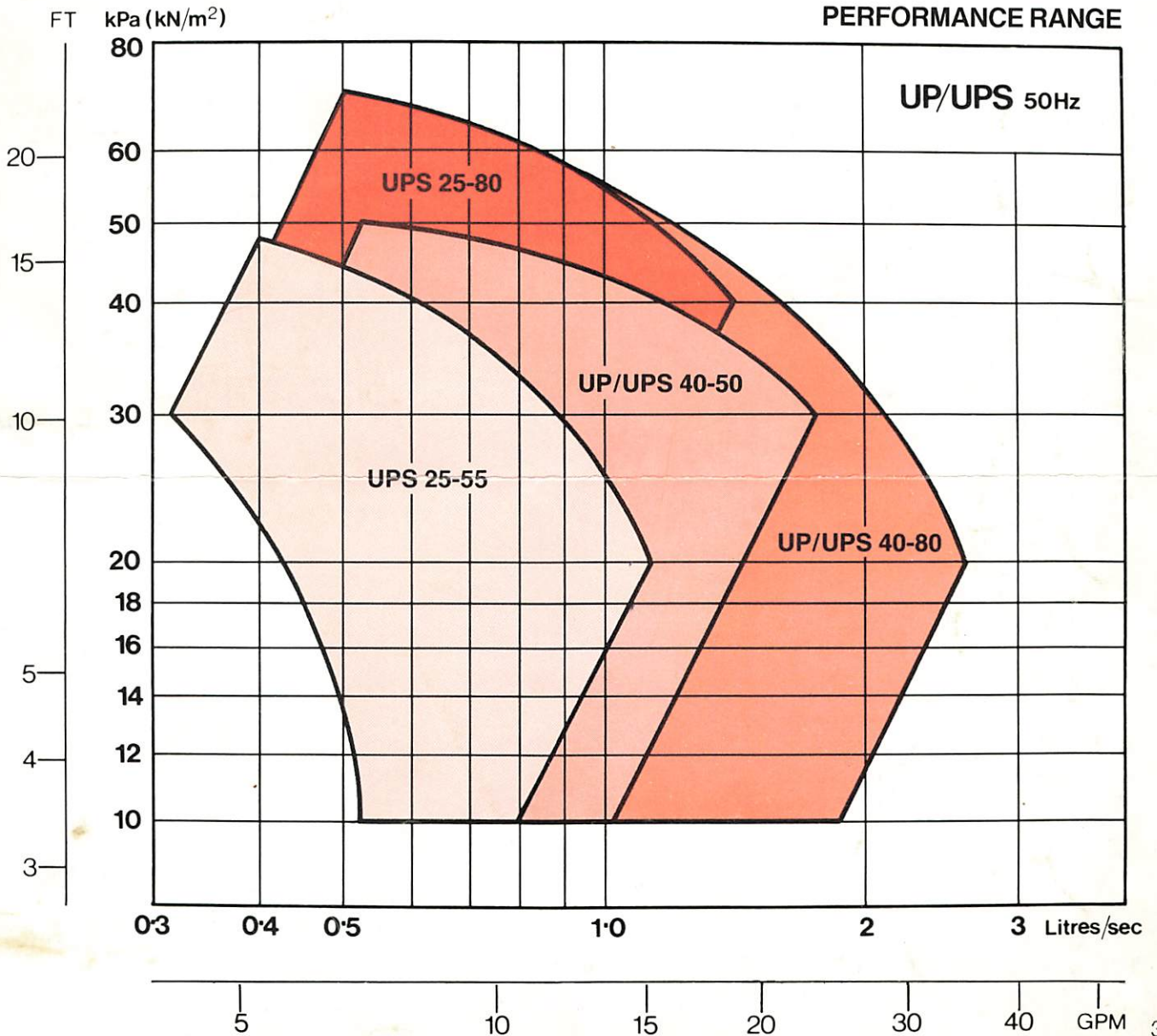

1 × 240V 50Hz MODELS

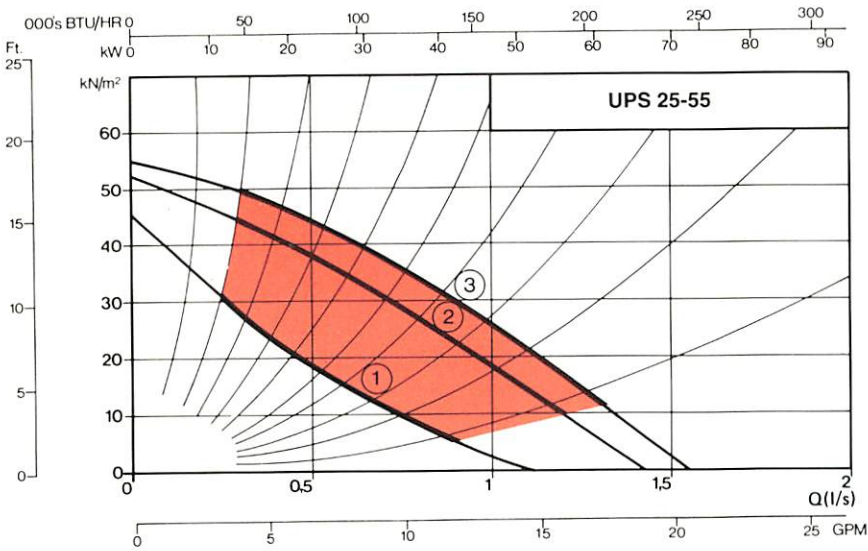

ELECTRICAL DATA

| SPEED | RPM | INPUT POWER WATTS | FULL LOAD CURRENT AMPS 1 × 240 VOLT | LOCKED ROTOR CURRENT AMPS |
|-------|------|-------------------|--|---------------------------|
| 3 | 2750 | 115 | 0.48 | 1.10 |
| 2 | 2500 | 100 | 0.44 | 0.81 |
| 1 | 1900 | 85 | 0.37 | 0.54 |

Capacitor Rating 3μF

WEIGHTS

| NET WEIGHT KG | GROSS WEIGHT KG | SHIPPING VOLUME M ³ |
|---------------|-----------------|--------------------------------|
| 4.2 | 4.5 | 0.0080 |

Pump selection should be within the shaded area, for optimum performance.

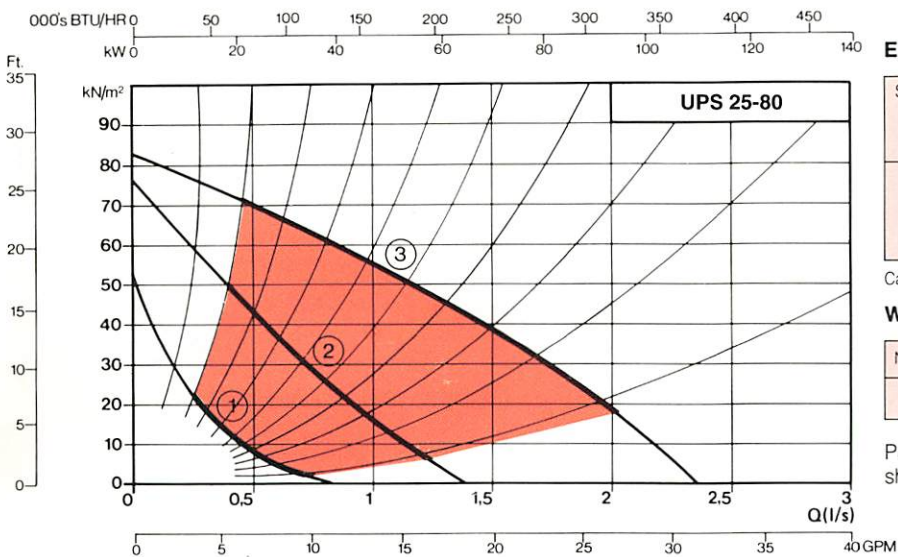

ELECTRICAL DATA

| SPEED | RPM | INPUT POWER WATTS | FULL LOAD CURRENT AMPS 1 × 240 VOLT | LOCKED ROTOR CURRENT AMPS |
|-------|------|-------------------|--|---------------------------|
| 3 | 2450 | 245 | 1.03 | 1.54 |
| 2 | 1650 | 210 | 0.91 | 1.10 |
| 1 | 1050 | 140 | 0.63 | 0.70 |

Capacitor Rating 5μF

WEIGHTS

| NET WEIGHT KG | GROSS WEIGHT KG | SHIPPING VOLUME M ³ |
|---------------|-----------------|--------------------------------|
| 4.2 | 4.5 | 0.0080 |

Pump selection should be within the shaded area, for optimum performance.

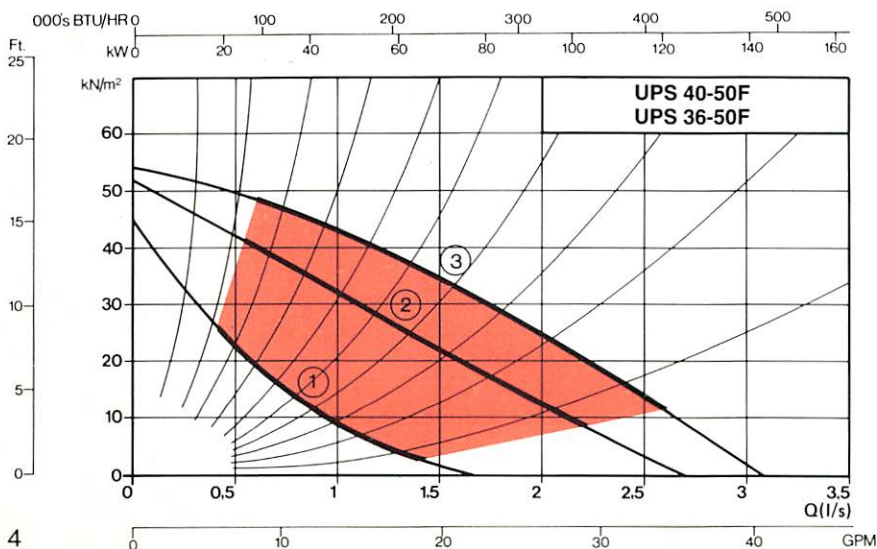

ELECTRICAL DATA

| SPEED | RPM | INPUT POWER WATTS | FULL LOAD CURRENT AMPS 1 × 240 VOLT | LOCKED ROTOR CURRENT AMPS |
|-------|------|-------------------|--|---------------------------|
| 3 | 2400 | 140 | 0.62 | 0.93 |
| 2 | 1650 | 125 | 0.57 | 0.66 |
| 1 | 1050 | 80 | 0.39 | 0.43 |

Capacitor Rating 3μF

WEIGHTS UPS36-50F

| NET WEIGHT KG | GROSS WEIGHT KG | SHIPPING VOLUME M ³ |
|---------------|-----------------|--------------------------------|
| 5.8 | 6.1 | 0.0102 |

WEIGHTS UPS40-50F

| NET WEIGHT KG | GROSS WEIGHT KG | SHIPPING VOLUME M ³ |
|---------------|-----------------|--------------------------------|
| 7.2 | 7.6 | 0.0122 |

Pump selection should be within the shaded area, for optimum performance.

3 × 415V 50Hz MODELS

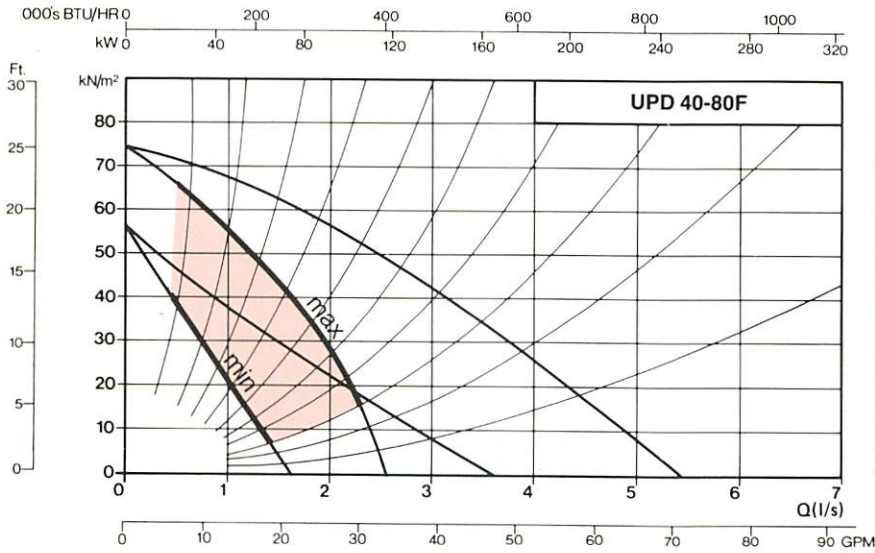

ELECTRICAL DATA

| RPM | INPUT POWER WATTS | FULL LOAD CURRENT AMPS 3 × 415 VOLT | LOCKED ROTOR CURRENT AMPS |
|------|-------------------|-------------------------------------|---------------------------|
| 2650 | 280 | 0.50 | 1.30 |

WEIGHTS

| NET WEIGHT KG | GROSS WEIGHT KG | SHIPPING VOLUME M ³ |
|---------------|-----------------|--------------------------------|
| 13.7 | 14.1 | 0.0126 |

Pump selection should be within the shaded area, for optimum performance.

- One pump head operating
- Both pump heads operating

DIMENSIONS

UPS 25-55 / UPS 25-80 WITH 1" BSPF UNIONS

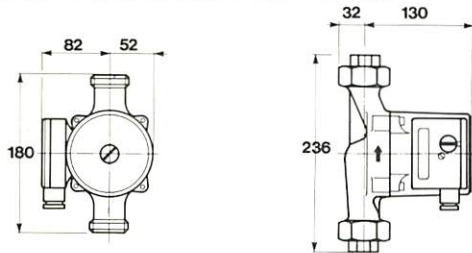

UPS 25-55 / UPS 25-80 WITH 1 1/4" BSPF UNIONS

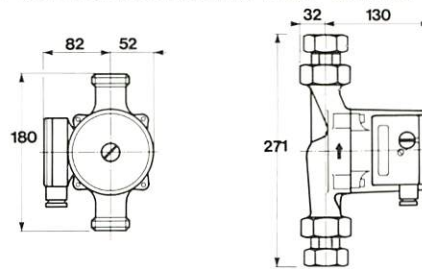

UPS 36-50F WITH 1 1/4", 1 1/2" OR 2" BSPF SQUARE FLANGES

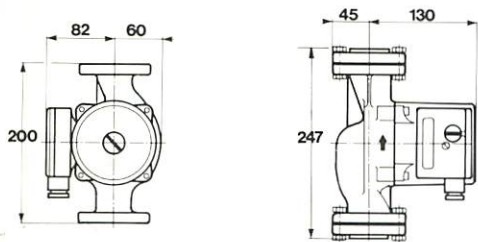

UPS 40-50F / UPS 40-80F WITH 1 1/2" OR 2" BSPF FLANGES

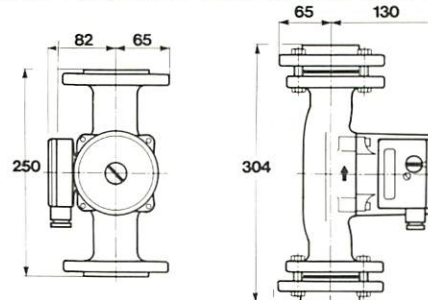

UP40-50F / UP 40-80F WITH 1 1/2" OR 2" BSPF FLANGES

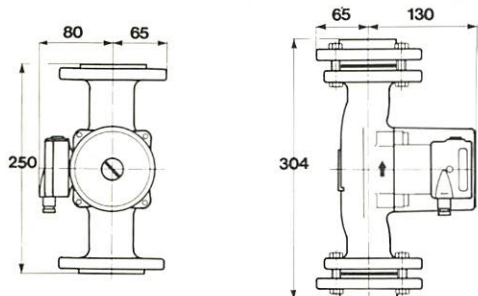

TWIN HEAD UPSD 40-50F / UPSD 40-80F WITH 1 1/2" OR 2" BSPF FLANGES

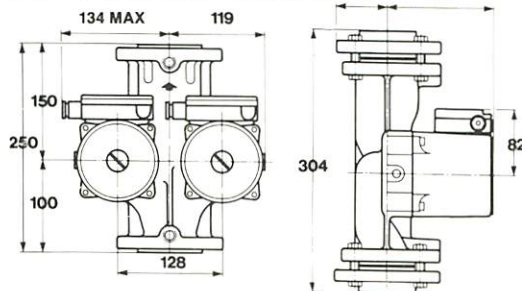

TWIN HEAD UPD 40-50F / UPD 40-80F WITH 1 1/2" OR 2" BSPF FLANGES

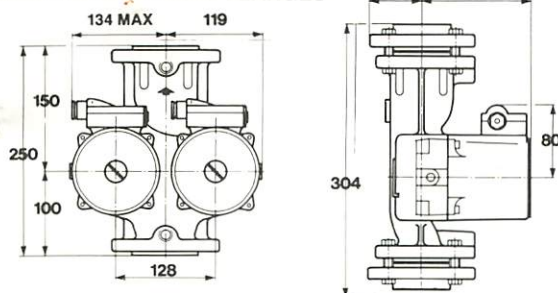

Suction/Discharge Flange Connections

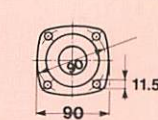

UPS 36/50F

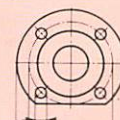

All UP 40 Models

TECHNICAL DATA

UP/UPS

MOTOR DATA

Standard voltages available are 240v 1ph 50Hz and 415v 3ph 50Hz.
 Motor enclosure class is: IP42 single phase; IP40 three phase
 Winding insulation is to Class F on all models.
 Cable connection: A Pg compression gland is fitted as standard on all terminal boxes to enable direct cable connection without the need for additional fittings.
 Single phase motors : Pg11 compression gland
 Three phase motors : Pg9 compression gland

MOTOR PROTECTION

All single phase models have internal motor protection by either thermal overload or impedance protection. Therefore no external motor protection is required for single phase motors.
 Three phase models must be connected to an approved starter incorporating low voltage release, overload protection and a single phasing prevention device.

INSTALLATION

It is preferable to install Grundfos circulators in a vertical pipe pumping upwards (see Fig. 1). This position ensures that the pump shaft is horizontal, which reduces the thrust bearing load and ensures positive air purging from both the rotor chamber and impeller housing.
 Pumping downwards in a vertical pipe is not recommended, as this may lead to air locking of the pump, with resultant loss of performance.

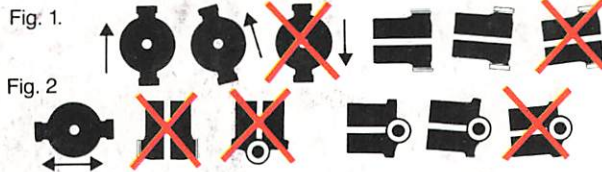

Where pumps can only be installed in horizontal pipework, it is imperative that the pump shaft is horizontal, or slightly higher at the vent plug end (see Fig 2.). The shaft must not fall below the horizontal plane, even by a few degrees, as this causes premature wear of the top bearing and shaft. Pumps must never be installed with the shaft in a vertical plane, as this may lead to dry running of the top bearing, noise and possible pump failure.

MAXIMUM OPERATING CONDITIONS

UPS 25 models are rated for a maximum system pressure of 10 Bars (145 psi). All UP/UPS 36 and 40 models are suitable for a maximum system pressure of 6 Bars (85 psi) except those models fitted with 2" BSPF counter flanges which have a 4 Bar rating (58 psi).

Water temperature range +15°C * to 110°C

* To avoid condensation in the motor windings the pumped liquid temperature must always be higher than the ambient temperature.

| Maximum Permissible Operating Temperatures | | | | | |
|--|-----|-----|-----|----|----|
| System Water Temperature °C | 110 | 105 | 100 | 90 | 80 |
| Ambient Temperature °C | 40 | 50 | 60 | 70 | 80 |

The minimum inlet pressure at 90°C water temperature should be 2.5m to avoid cavitation and to ensure quiet running for all models.

FLOW ADJUSTMENT

On single phase models flow can be adjusted by changing the speed to one of three settings by means of a selectric switch.

Three phase models are variable flow pumps on a fixed speed setting. On the bottom of the pump case, there is a mechanical flow adjuster with five settings.

TWIN HEAD MODELS

For Twin Head models installed in horizontal pipes, it is recommended that an automatic air vent (1/8" BSP) is fitted as shown.

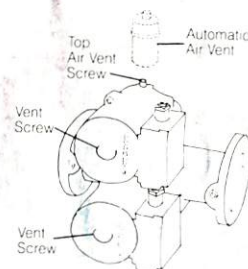

GRUNDFOS PUMPS LTD

Head Office: Grovebury Road, Leighton Buzzard, Bedfordshire LU7 8TL. Telephone (0525) 850000. Telex 825544. Facsimile (0525) 850011.
Northern Area Sales Office: Gawsorth Court, Rislely Road, Rislely, Warrington, Cheshire WA3 6NJ. Telephone (0925) 813300. Telex 628162. Facsimile (0925) 830014.
South East Service Depot: Unit 13a, Dartford Trade Park, Powder Mill Lane, Dartford, Kent DA1 1NX. Telephone (0322) 92422. Facsimile (0322) 91025.

SITING THE PUMP

- To avoid sediment, do not fit the pump in lowest point of system.
- Fit isolating valves on either side of the pump.
- To prevent noise, avoid sharp bends either side of the pump.
- Position the motor away from heat sources and allow access for removing pump head from base.
- Always try to ensure that the terminal box is not adjacent to hot surfaces. On UPS models the selectric switch should be readily available for adjustment of pump speed.
- In open-vented systems, position the pump so that it neither pumps over into feed/expansion tank, nor sucks air down the vent pipe. Generally this means fitting the pump in the flow pipe, with the vent on the inlet side of the pump.
- In sealed systems, the pump can be fitted in flow or return pipes as required.
- In systems where all the flow can be stopped while the pump is still running, e.g. systems fitted with thermostatic valves, a by-pass should be fitted between flow and return lines to ensure water flow through the pump at all times (approx. 7.5% of maximum pump capacity).
- Ensure the pump is not stressed by the pipework and that the pipework is properly supported either side of the pump.

SUCTION/DISCHARGE PIPE CONNECTIONS

| MODEL | PUMP CONNECTION | PIPE CONNECTION |
|---|---|--|
| UPS 25-55 | 1½" BSPM | 1¼" BSPF Unions (Standard) |
| UPS 25-80 | 1½" BSPM | or 1" BSPF Unions (Optional on request) |
| UPS 36-50F | 4 Bolt Square Flange | 1¼" BSPF Counter Flange (Optional on request) 1½" BSPF Counter Flange 2" BSPF Counter Flange |
| UP(D) UPS(D) 40-50F and 40-80F | Flange to BS4504 1969 table 6/11 N.B. 40mm | 1½" BSPF Counter Flange (Standard) to BS4504 1969 table 6/4. or 2" BSPF Counter Flange to same standard, bored & screwed to 2" BSPF (Optional but with a 4 bar rating on request) |

TYPE DESIGNATION

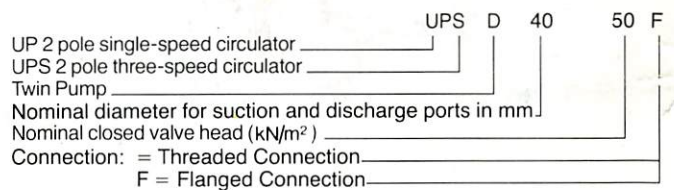

PUMP MATERIAL SPECIFICATION

| | | |
|-----------------|-------------------|------------------|
| Pump Housing | : Cast Iron | BS1452 Grade 180 |
| Stator Housing | : Aluminium Alloy | |
| Shaft | : Ceramic | |
| Impeller | : Stainless Steel | BS1449 304 S15 |
| Split Cone | : Stainless Steel | BS1449 304 S15 |
| Neck Ring | : Stainless Steel | BS1449 304 S15 |
| Rotor Can | : Stainless Steel | BS1449 304 S15 |
| Rotor Cladding | : Stainless Steel | BS1449 304 S15 |
| 'O' Rings | : EPDM Rubber | |
| Radial Bearings | : Ceramic | |
| Axial Bearing | : Carbon | |

It is the continuing policy of Grundfos to develop and improve our products, and we reserve the right to amend prices and specification without prior notice.

UP/UPS 5/89

GRUNDFOS

